

Industrial Controls

Soft starters SIRIUS 3RW30 / 3RW40

Equipment Manual

Introduction	1
Safety information	2
Product description	3
Functions	4
Messages and diagnosis	5
Application planning	6
Installation	7
Installation / mounting	8
Connecting	9
Operation	10
Configuration	11
Commissioning	12
Technical data	13
Dimension drawings	14
Typical circuit diagrams	15
Appendix	A

Legal information

Warning notice system

This manual contains notices you have to observe in order to ensure your personal safety, as well as to prevent damage to property. The notices referring to your personal safety are highlighted in the manual by a safety alert symbol, notices referring only to property damage have no safety alert symbol. These notices shown below are graded according to the degree of danger.

 DANGER
indicates that death or severe personal injury will result if proper precautions are not taken.

 WARNING
indicates that death or severe personal injury may result if proper precautions are not taken.

 CAUTION
indicates that minor personal injury can result if proper precautions are not taken.

NOTICE
indicates that property damage can result if proper precautions are not taken.

If more than one degree of danger is present, the warning notice representing the highest degree of danger will be used. A notice warning of injury to persons with a safety alert symbol may also include a warning relating to property damage.

Qualified Personnel

The product/system described in this documentation may be operated only by **personnel qualified** for the specific task in accordance with the relevant documentation, in particular its warning notices and safety instructions. Qualified persons are those who, because of their training and experience, are familiar with the installation, assembly, commissioning, operation, decommissioning and disassembly of the product and can recognize risks and avoid possible hazards.

Proper use of Siemens products

Note the following:

 WARNING
Siemens products may only be used for the application described in the catalog and the associated usage information. If products and components from other manufacturers are used, these must be recommended or approved by Siemens. Proper transport, storage, installation, assembly, commissioning, operation and maintenance are required to ensure that the products operate safely and without any problems. The permissible ambient conditions must be complied with. The information in the relevant documentation must be observed.

Trademarks

All names identified by ® are registered trademarks of Siemens Aktiengesellschaft. The remaining trademarks in this publication may be trademarks whose use by third parties for their own purposes could violate the rights of the owner.

Disclaimer of Liability

We have reviewed the contents of this publication to ensure consistency with the hardware and software described. Since variance cannot be precluded entirely, we cannot guarantee full consistency. However, the information in this publication is reviewed regularly and any necessary corrections are included in subsequent editions.

Table of contents

1	Introduction	9
1.1	Important notes	9
1.2	Additional documentation	11
1.3	Siemens SiePortal Support	12
1.4	Siemens Industry Online Support app.....	14
1.5	Support Request	15
1.6	Change documentation	16
2	Safety information	17
2.1	ESD Guidelines.....	17
2.2	Reactive power compensation.....	21
2.3	Electromagnetic compatibility (EMC) according to IEC 60947-4-1	22
2.4	Cybersecurity information.....	23
2.5	Recycling and disposal	24
2.6	Before commencing work: Isolating the equipment from the supply system and ensuring that it cannot be reconnected.	25
2.7	Five safety rules for work in or on electrical systems	26
3	Product description	27
3.1	Fields of application	27
3.2	Functional principle of the SIRIUS 3RW30 and 3RW40 soft starters	28
3.2.1	Method of operation of a two-phase controlled soft starter.....	30
3.2.2	Starting current asymmetry.....	31
3.2.3	Applications and use	32
3.3	Accessories	34
3.3.1	Accessories for 3RW30 soft starters	34
3.3.2	Accessories for 3RW40 soft starters	35
4	Functions	37
4.1	Start modes	37
4.1.1	Voltage ramp	37
4.1.2	Current limiting and ramp-up detection (3RW40 only)	40
4.2	Stop modes	42
4.2.1	Stop without load (3RW30 and 3RW40).....	42
4.2.2	Soft stop (3RW40 only)	43
4.3	Motor protection / intrinsic device protection (3RW40 only)	44
4.3.1	Motor protection function.....	44
4.3.2	ATEX / IECEx for sizes S0 to S3	46

4.3.3	Intrinsic device protection (3RW40 only).....	48
4.4	Functions of the RESET buttons	49
4.4.1	SIRIUS 3RW402, 3RW403 and 3RW404 soft starters	49
4.4.1.1	Setting the RESET MODE	49
4.4.1.2	Manual RESET	49
4.4.1.3	Remote RESET	50
4.4.1.4	Auto RESET	50
4.4.1.5	Acknowledging faults	50
4.4.2	Other functions of the RESET button	51
4.4.2.1	Motor protection trip test	51
4.4.2.2	Reparameterizing the ON / RUN output contact	51
4.4.3	Reset options for fault acknowledgement	51
4.5	Functions of the inputs	52
4.5.1	Start input (terminal 1) on 3RW30 and 3RW402 to 3RW404	52
4.5.2	Thermistor input / connection on 3RW402 to 3RW404	52
4.6	Functions of the outputs	53
4.6.1	3RW30: Output terminal 13 / 14 ON	53
4.6.2	3RW40: Output terminals 13 / 14 ON / RUN and 23 / 24 BYPASSED	53
4.6.3	3RW40: Group fault output at terminal 95 / 96 / 98 OVERLOAD / FAILURE	55
5	Messages and diagnosis	57
5.1	3RW30: LEDs	57
5.2	3RW30: Troubleshooting	58
5.3	3RW402 / 3RW403 / 3RW404: LEDs	59
5.4	3RW40: Troubleshooting	61
6	Application planning	63
6.1	Application examples	63
6.1.1	Roller conveyor application	63
6.1.2	Hydraulic pump application.....	64
7	Installation.....	65
7.1	Installing the soft starter	65
7.1.1	Unpacking	65
7.1.2	Permissible mounting position	65
7.1.3	Mounting dimensions, clearances, and assembly type	66
7.1.4	Assembly type: Standalone assembly, side-by-side assembly, direct mounting	67
7.1.5	Installation requirements	68
8	Installation / mounting	69
8.1	General information.....	69
8.2	General feeder assembly (type of coordination 1).....	70
8.3	Soft starter with line contactor (type of coordination 1).....	71
8.4	Soft starter assembly with type of coordination 2	72
8.5	Capacitors to improve the power factor	74
8.6	Maximum cable length	75

9	Connecting	77
9.1	Electrical connection	77
9.1.1	Control and auxiliary terminals.....	77
9.1.2	Main circuit connection.....	77
10	Operation.....	79
10.1	Operator controls, displays, and connections on the 3RW30	79
10.2	Operator controls, displays, and connections on the 3RW40	80
10.3	Effects on changing the potentiometer settings	82
11	Configuration.....	83
11.1	Configuration in general	83
11.1.1	Configuration procedure	83
11.1.2	Selecting the optimum soft starter	84
11.2	Startup class	86
11.2.1	Application examples for normal starting (CLASS 10) with 3RW30 and 3RW40.....	86
11.2.2	Application examples for heavy-duty starting (CLASS 20): 3RW40 only	87
11.3	ON time and switching frequency	89
11.4	Reducing the rated data	90
11.5	Dimensioning of soft starters for motors with high starting current conditions.....	91
11.6	Installation altitude and ambient temperature	92
11.7	Calculating the permissible switching frequency.....	94
11.7.1	Table of permissible assembly combinations with switching frequency factors	94
11.7.2	Calculating the switching frequency (example).....	97
11.8	Configuration aids.....	99
11.8.1	Selection of the soft starter using the Simulation Tool for Soft Starters.....	99
11.9	Article number system for the 3RW30	100
11.10	Article number system for the 3RW40	101
12	Commissioning	103
12.1	Commissioning the 3RW30	103
12.1.1	Commissioning procedure.....	103
12.1.2	Quick commissioning of the 3RW30 and optimization of the parameters.....	104
12.1.3	Setting the soft start function	105
12.1.4	Setting the starting voltage.....	106
12.1.5	Setting the ramp time	106
12.1.6	ON output	107
12.2	Commissioning the 3RW40	108
12.2.1	Commissioning procedure.....	108
12.2.2	Quick commissioning of the 3RW40 and optimization of the parameters.....	109
12.2.3	Setting the soft start function	110
12.2.4	Setting the starting voltage.....	111
12.2.5	Setting the ramp time	111
12.2.6	Current limiting in conjunction with a starting voltage ramp and ramp-up detection	112
12.2.7	Setting the motor current.....	112

12.2.8	Setting the current limiting value	113
12.2.9	Optimized setting ranges for current limiting.....	114
12.2.10	Ramp-up detection.....	115
12.3	Setting the soft stop function.....	116
12.3.1	Setting the ramp-down time	116
12.4	Setting the motor protection function	117
12.4.1	Setting the electronic motor overload protection	117
12.4.2	Motor current settings	118
12.4.3	Motor protection acc. to ATEX	118
12.5	Thermistor motor protection	119
12.6	Motor protection trip test.....	120
12.7	Functions of the outputs	121
12.7.1	Functions of the BYPASSED and ON / RUN outputs	121
12.7.2	Parameterizing the 3RW40 outputs	122
12.7.3	Function of the FAILURE / OVERLOAD output.....	124
13	Technical data	125
13.1	Technical specifications in the Siemens SiePortal	125
13.2	3RW30	126
13.2.1	Overview	126
13.2.2	3RW30..-BB.. control electronics.....	127
13.2.3	3RW30..-BB.. control times and parameters	127
13.2.4	3RW30..-BB.. power electronics.....	128
13.2.5	3RW30 13, 14, 16, 17, 18-.BB.. power electronics.....	128
13.2.6	3RW30 26, 27, 28-.BB.. power electronics	129
13.2.7	3RW30 36, 37, 38, 46, 47-.BB.. power electronics.....	129
13.2.8	3RW30 main conductor cross-sections.....	130
13.2.9	3RW30 auxiliary conductor cross-sections	131
13.2.10	Electromagnetic compatibility according to EN 60947-4-2	131
13.2.11	Recommended filters	132
13.2.12	Types of coordination.....	132
13.2.13	More information on configuration	133
13.3	3RW40	134
13.3.1	Overview	134
13.3.2	3RW40 2., 3., 4. control electronics	135
13.3.3	3RW40 2., 3., 4. control electronics	135
13.3.4	3RW40 protection functions.....	136
13.3.5	3RW40 control times and parameters.....	136
13.3.6	3RW40 power electronics.....	137
13.3.7	3RW40 24, 26, 27, 28 power electronics	138
13.3.8	3RW40 36, 37, 38, 46, 47 power electronics	139
13.3.9	3RW40 2., 3., 4. main conductor cross-sections	140
13.3.10	3RW40 .. auxiliary conductor cross-sections.....	141
13.3.11	Electromagnetic compatibility according to EN 60947-4-2	141
13.3.12	Recommended filters	142
13.3.13	Types of coordination.....	142
13.3.14	More information on configuration	143
13.3.15	Motor protection tripping characteristics for 3RW40 (with symmetry)	143
13.3.16	Motor protection tripping characteristics for 3RW40 (with asymmetry)	144

14	Dimension drawings	145
14.1	CAx data in the Siemens SiePortal	145
15	Typical circuit diagrams	147
15.1	Typical circuit for the optional thermistor motor protection evaluation	147
15.2	Control by pushbutton	148
15.2.1	Control of the 3RW30 by pushbutton.....	148
15.2.2	Control of the 3RW40 by pushbutton.....	149
15.3	Control by switch	150
15.3.1	Control of the 3RW30 by switch	150
15.3.2	Control of the 3RW40 by switch	151
15.4	Control in automatic mode.....	152
15.4.1	Control of the 3RW30 in automatic mode	152
15.4.2	Control of the 3RW40 in automatic mode	153
15.5	Control by PLC	155
15.5.1	Control of the 3RW30 with 24 V DC by PLC	155
15.5.2	Control of the 3RW40 by PLC.....	156
15.6	Control with an optional main / line contactor	157
15.6.1	Control of the 3RW30 with a main contactor	157
15.6.2	Control of the 3RW40 with a main contactor	158
15.7	Reversing circuit.....	159
15.7.1	3RW30 reversing circuit	159
15.7.2	3RW40 reversing circuit	160
15.8	Control of a magnetic parking brake	162
15.8.1	3RW30 motor with magnetic parking brake	162
15.8.2	3RW402 - 3RW404, control of a motor with a magnetic parking brake	163
15.9	EMERGENCY STOP.....	164
15.9.1	3RW30 EMERGENCY STOP and 3SK1 safety relay.....	164
15.9.2	3RW402 - 3RW404 EMERGENCY STOP and 3SK1 safety relay	165
15.10	3RW and contactor for emergency starting	167
15.10.1	3RW30 and contactor for emergency starting	167
15.10.2	3RW40 and contactor for emergency starting	168
15.11	Dahlander / multispeed motor	169
15.11.1	3RW30 and Dahlander motor starting	169
15.11.2	3RW402 - 3RW404 and Dahlander motor starting	170
A	Appendix	173
A.1	Configuration data	173
A.2	Table of parameters used	175
	Index	177

Introduction

1.1 Important notes

Purpose of this manual

This manual contains fundamental information and practical tips for using SIRIUS soft starters. The SIRIUS 3RW30 and 3RW40 soft starters are electronic motor control devices that facilitate optimal starting and stopping three-phase induction motors. The manual describes all of the functions of the SIRIUS 3RW30 and 3RW40 soft starters.

Target group

This manual is intended for any user involved in

- Commissioning
- Servicing and maintenance
- Planning and configuring systems

Basic knowledge required

A general knowledge of the field of electrical engineering is required to understand this manual.

Scope of validity

The manual is valid for the SIRIUS 3RW30 and 3RW40 soft starters. It describes the components that are valid at the time of publication. SIEMENS reserves the right to include a Product Information for each new component, and for each component of a later version.

Standards and approvals

The SIRIUS 3RW30 and 3RW40 soft starters are based on the IEC/EN 60947-4-2 standard.

Disclaimer of liability

It is the responsibility of the manufacturer to ensure that a system or machine is functioning properly as a whole. SIEMENS AG, its regional offices, and associated companies (hereinafter referred to as "SIEMENS") cannot guarantee all the properties of a whole plant system or machine that has not been designed by SIEMENS.

Similarly, SIEMENS can assume no liability for recommendations that appear or are implied in the following description. No new guarantee, warranty, or liability claims beyond the scope of the SIEMENS general terms of supply are to be derived or inferred from the following description.

Orientation aids

The manual contains various features supporting quick access to specific information:

- At the beginning of the manual you will find a table of contents.
- A comprehensive index at the end of the manual allows quick access to information on specific subjects.

Selection data and ordering data

You can find additional information about soft starters on the Internet in the Industry Mall.

Here, you have access to

- Catalogs/brochures (<https://support.industry.siemens.com/cs/ww/en/ps/25247/cat>)
- Online configuration (<http://www.siemens.com/sirius/configurators>)

1.2 Additional documentation

Manuals/operating instructions

At this point, you will find further manuals and operating instructions that may be of interest to you for your automation system. They are available to download from the Internet free of charge. You can create your own individual system documentation in mySupport.

- SIRIUS 3RW301/302/303/304 soft starters (<https://support.industry.siemens.com/cs/document/26378636>)
- Semiconductor motor controllers (<https://support.industry.siemens.com/cs/document/9835687>)
- SIRIUS semiconductor motor controllers (<https://support.industry.siemens.com/cs/document/6015580>)
- SIRIUS 3RW40 soft starters - Safety and commissioning instructions for hazardous areas (<https://support.industry.siemens.com/cs/document/22809303>)
- 3RW5 overview page (<https://support.industry.siemens.com/cs/ww/en/view/109747404>)

Interesting links

- Catalog with information on configuration (<https://support.industry.siemens.com/cs/ww/en/view/109747945>)
- FAQs on 3RW soft starters (<https://support.industry.siemens.com/cs/ww/de/ps/16212/faq>)
- Downloads relating to 3RW soft starters (<https://support.industry.siemens.com/cs/ww/de/ps/16212/dl>)
- Manuals in Siemens Industry Online Support (<https://support.industry.siemens.com/cs/ww/de/ps/man>)
- More information on PROFINET (<https://www.siemens.com/en-us/products/profinet/>)

1.3 Siemens SiePortal Support

At Siemens SiePortal Support you can obtain up-to-date information from our global support database: You can also define your personal workspace.

Support

You can find information and comprehensive know-how covering all aspects of your product here:

- **Solution Guide**
Our AI functionality answers your questions based on verified technical product information.
- **Manuals/operating instructions**
Read online or download, available as PDF or individually configurable.
- **Downloads**
Here you will find updates, service packs, HSPs and much more for your product.
- **Certificates**
Clearly sorted according to approving authority, type and country.
- **Characteristics**
For support in planning and configuring your system.
- **Catalogs / Brochures**
Read online or download, available as PDF.
- **Technical data**
Technical product data for support in planning and implementing your project
- **Product announcements**
The latest information and news concerning our products.
- **Forum**
Harness the potential of our community.
- **FAQs**
Answers to frequently asked questions
- **Application examples**
Function blocks, background and system descriptions, performance statements, demonstration systems, and application examples, clearly explained and represented.

Link: Siemens SiePortal Support (<https://support.industry.siemens.com/cs/de/en>)

mySiePortal

The following functions are available in your personal work area "mySiePortal":

- **My conversations**
Overview of your previous conversations.
- **Installed products**
Your registered products are displayed here.
- **Service requests**
Overview of your previous support requests.

- **Lists & notifications**
Here you can view your search queries, favorites, notifications and lists of products.
- **Product data & documentation**
Easy access to CAx data, e.g. 3D models, 2D dimension drawings, EPLAN macros, device circuit diagrams
- **My Quicklinks**
Compile a list of frequently used links to access information more quickly.

1.4 Siemens Industry Online Support app

Siemens Industry Online Support app

The Siemens Industry Online Support app provides you access to all the device-specific information available on the Siemens Industry Online Support portal for a particular article number, such as operating instructions, manuals, data sheets, FAQs etc.

The Siemens Industry Online Support app is available for Android and iOS:



Android



iOS

1.5 Support Request

You can submit and manage support requests in the mySupport Cockpit. To do this, you must register once.

Support request:	Internet (https://www.siemens.com/support-request)
-------------------------	--

1.6 Change documentation

Version	Changes
02/2026	Information on ATEX updated

Safety information

2.1 ESD Guidelines

ESD

All electronic devices are equipped with large-scale integrated ICs or components. Due to their design, these electronic elements are highly sensitive to overvoltage, and thus to any electrostatic discharge.

ESD devices are identified by the following symbol:



NOTICE

Electrostatic discharge

ESD devices can be destroyed by voltages well below the threshold of human perception. These static voltages develop when you touch a component or electrical connection of a device without having drained the static charges present on your body. The damage caused to a device by overvoltage is usually not immediately evident and is only noticed after an extended period of operation.

Electrostatic charging

Anyone who is not connected to the electrical potential of their surroundings can be electrostatically charged.

The diagram below shows the maximum electrostatic voltage which may build up on a person coming into contact with the materials specified in the diagram. These values are in conformity with the specifications of IEC 61000-4-2.

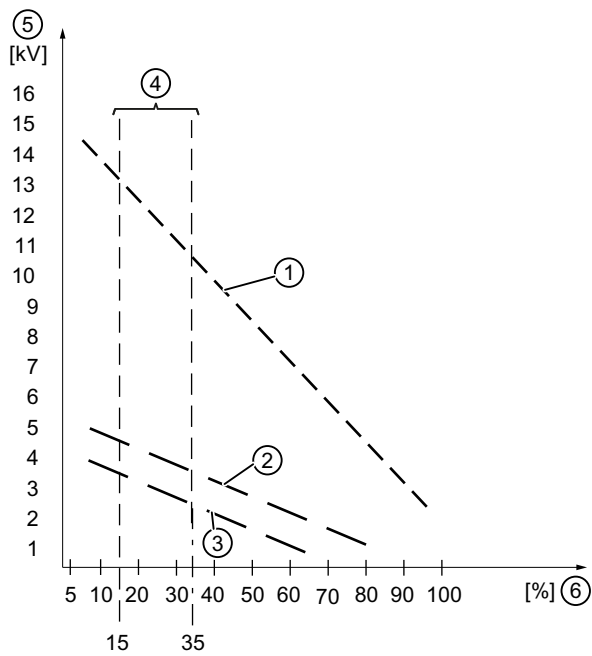

- ① Synthetic material
- ② Wool
- ③ Antistatic material, e.g. wood or concrete
- ④ E.g. office spaces without humidity control (in winter)
- ⑤ Voltage
- ⑥ Relative humidity

NOTICE**Protective measures against damage to equipment due to discharge of static electricity**

Electronic devices contain components that can be damaged by electrostatic discharge if they are handled improperly.

- **Grounding/discharge**

When handling electrostatic sensitive devices, ensure that your body, the workplace, and packaging are grounded. In this way, you can avoid becoming electrostatically charged. Discharge your body electrostatically immediately before touching an electronic component. To do this, touch a conductive, grounded object, e.g., a bare metal part of a switch cabinet or the water pipe.

Electrostatically sensitive devices should not be brought into contact with electrically insulating materials such as plastic film, plastic parts, insulating table supports, or clothing made of synthetic fibers.

- **Direct contact**

Only touch electrostatic sensitive devices when this is unavoidable (e.g. during maintenance work). Handle the devices, if possible, only by the plastic enclosure and without touching any chip pins or PCB traces. In this way, the discharged energy cannot reach or damage sensitive devices.

Discharge your body before taking any necessary measurements on a device. Do so by touching grounded metallic parts. Use only grounded measuring instruments.

Always place an electrostatic sensitive device on conductive bases.

- **Storage and transport**

Always store and transport electrostatic sensitive devices or components in ESD-safe conductive packaging, e.g. metallized plastic or metal containers. Leave the device in its packaging until installation.

NOTICE**Storage and transport in non-conductive packaging**

If you have to store or transport the electrostatic sensitive device in non-conductive packaging, you must first pack the device in ESD-safe, conductive material, e.g., conductive foam rubber, ESD bag.

The diagrams below illustrate the required ESD protective measures for electrostatic sensitive devices.

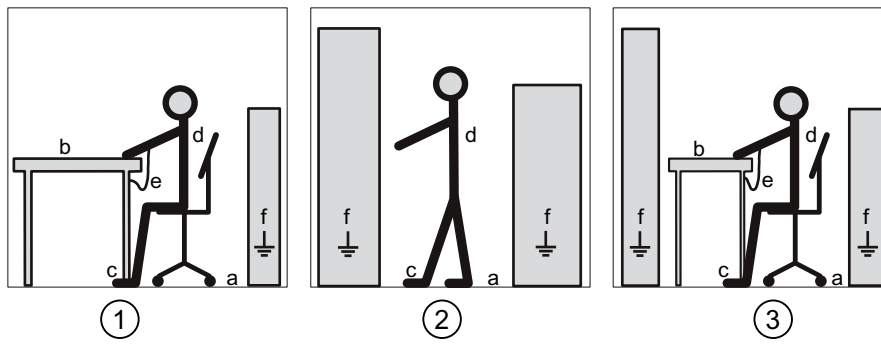

- ① ESD seat
- ② ESD standing position
- ③ ESD seat and ESD standing position

Protective measures

- a Conductive floor
- b ESD table
- c ESD shoes
- d ESD smock
- e ESD bracelet
- f Cabinet ground connection

2.2 Reactive power compensation

Capacitors for improving the power factor (reactive power compensation)

Capacitors must not be connected to the output terminals of the 3RW30/40 Soft Starter. If there is a connection to the output terminals, the 3RW30/40 Soft Starter will be damaged.

Active filters, e.g. for reactive power compensation, must not be operated parallel to the motor control device.

If capacitors are to be used to correct the power factor (actively or passively), they must be connected on the line side of the device. They must not actively control the power factor during the starting and coasting down phases. If an isolating contactor or main contactor are used together with the electronic 3RW30/40 Soft Starter, the capacitors must be disconnected from the 3RW30/40 Soft Starter when the contactor is open.

2.3 Electromagnetic compatibility (EMC) according to IEC 60947-4-1

This product is designed for Environment A. It may produce radio interference in domestic environments, in which case the user may be required to take adequate mitigation measures.

2.4 Cybersecurity information

Siemens provides products and solutions with industrial cybersecurity functions that support the secure operation of plants, systems, machines and networks.

In order to protect plants, systems, machines and networks against cyber threats, it is necessary to implement – and continuously maintain – a holistic, state-of-the-art industrial cybersecurity concept. Siemens' products and solutions constitute one element of such a concept.

Customers are responsible for preventing unauthorized access to their plants, systems, machines and networks. Such systems, machines and components should only be connected to an enterprise network or the internet if and to the extent such a connection is necessary and only when appropriate security measures (e.g. firewalls and/or network segmentation) are in place.

For additional information on industrial cybersecurity measures that may be implemented, please visit <https://www.siemens.com/cybersecurity-industry>.

Siemens' products and solutions undergo continuous development to make them more secure. Siemens strongly recommends that product updates are applied as soon as they are available and that the latest product versions are used. Use of product versions that are no longer supported, and failure to apply the latest updates may increase customer's exposure to cyber threats.

To stay informed about product updates, subscribe to the Siemens Industrial Cybersecurity RSS Feed under <https://www.siemens.com/cert>.

2.5 Recycling and disposal

For environmentally-friendly recycling and disposal of your old device, contact a company certified for the disposal of used electrical and electronic equipment, and dispose of the device as specified in the regulations for your particular country.

2.6 Before commencing work: Isolating the equipment from the supply system and ensuring that it cannot be reconnected.

2.6 Before commencing work: Isolating the equipment from the supply system and ensuring that it cannot be reconnected.

DANGER

Hazardous voltage Will cause death or serious injury.

- Disconnect the system and all devices from the power supply before starting work.
- Secure against switching on again.
- Verify that the equipment is not live.
- Ground and short-circuit.
- Erect barriers around or cover adjacent live parts.

DANGER

Hazardous voltage Will cause death or serious injury.

Qualified Personnel.

The equipment / system may only be commissioned and operated by qualified personnel. For the purpose of the safety information in these Operating Instructions, a "qualified person" is someone who is authorized to energize, ground, and tag equipment, systems, and circuits in accordance with established safety procedures.

2.7 Five safety rules for work in or on electrical systems

A set of rules, which are summarized in DIN VDE 0105 as the "five safety rules", are defined for work in or on electrical systems as a preventative measure against electrical accidents:

1. Isolate
2. Secure against switching on again
3. Verify that the equipment is not live
4. Ground and short-circuit
5. Erect barriers around or cover adjacent live parts

These five safety rules must be applied in the above order prior to starting work on an electrical system. After completing the work, proceed in the reverse order.

It is assumed that every electrician is familiar with these rules.

Explanations

1. The isolating distances between live and deenergized parts of the system must vary according to the operating voltage that is applied.
"Isolate" refers to the all-pole disconnection of live parts.
All-pole disconnection can be achieved, e.g. by.:
 - Switching off the miniature circuit breaker
 - Switching off the motor circuit breaker
 - Unscrewing fusible links
 - Removing LV HRC fuses
2. The feeder must be secured against inadvertent restarting to ensure that it remains isolated for the duration of the work. This can be achieved, for instance, by securing the motor and miniature circuit breakers with lockable blocking elements in the disconnected state, either using a lock or by unscrewing the fuses.
3. The deenergized state of the equipment should be verified using suitable test equipment, e.g. a two-pole voltmeter. Single-pole test pins are not suitable for this purpose. The absence of power must be established for all poles, phase to phase, and phase to N/PE.
4. Grounding and short-circuiting are only mandatory if the system has a nominal voltage greater than 1 kV. In this case, the system should always be grounded first and then connected to the live parts to be short-circuited.
5. These parts should be covered, or barriers erected around them, to avoid accidental contact during the work with adjacent parts that are still live.

Product description

3.1 Fields of application

3RW30

The SIRIUS 3RW30 Basic Performance soft starters are suitable for soft starting of three-phase asynchronous motors. Thanks to 2-phase control, not only is the current kept at minimum values in all three phases throughout the entire ramp-up time, but interfering direct current components are also eliminated. This not only enables the 2-phase starting of motors up to 55 kW (at 400 V), but also avoids the current and torque peaks that occur, for example, with wye-delta starters.

3RW40

The SIRIUS 3RW40 Basic Performance soft starters are suitable for soft starting and stopping of three-phase asynchronous motors. Thanks to 2-phase control, not only is the current kept at minimum values in all three phases throughout the entire ramp-up time, but interfering direct current components are also eliminated. This not only enables the 2-phase starting of motors up to 55 kW (at 400 V), but also avoids the current and torque peaks that occur, for example, with wye-delta starters.

3.2 Functional principle of the SIRIUS 3RW30 and 3RW40 soft starters

The SIRIUS 3RW30 and 3RW40 soft starters have two antiparallel thyristors in two out of the three phases. One thyristor for the positive half-wave and one for the negative half-wave is provided in each phase (refer to Fig. "Phase angle control and schematic diagram of a two-phase controlled soft starter with integral bypass contacts"). The current in the third, uncontrolled phase is the sum of the currents in the controlled phases.

The rms value of the motor voltage is increased (from a settable starting voltage) to the rated motor voltage within a definable starting time by means of the phase angle control.

The motor current changes in proportion to the voltage applied to the motor. As a result, the starting current is reduced by the factor of this voltage.

There is a quadratic relationship between the torque and the voltage applied to the motor. As a result, the starting torque is reduced quadratically in relation to this voltage.

Example

SIEMENS 1LG4253AA motor (55 kW)

Rated data at 400 V

P_e :	55 kW
I_e :	100 A
$I_{\text{direct starting}}$:	Approx. 700 A
M_e :	355 Nm; e.g.: $M_e = 9.55 \times 55 \text{ kW} \times \frac{1000}{1480 \text{ min}^{-1}}$
n_e :	1480 rpm
$M_{\text{direct starting}}$:	Approx. 700 Nm
Set starting voltage:	50 % ($\frac{1}{2}$ of mains voltage)
$\Rightarrow I_{\text{starting}}$	$\frac{1}{2}$ of direct starting current (approx. 350 A)
$\Rightarrow M_{\text{starting}}$	$\frac{1}{4}$ of direct starting torque (approx. 175 Nm)

The diagrams below show the starting current and torque characteristics for a three-phase induction motor in combination with a soft starter:

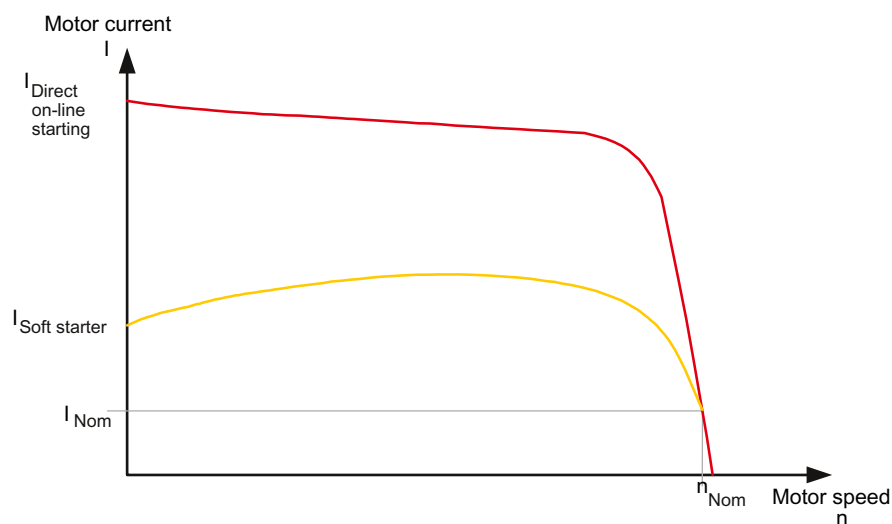

Figure 3-1 Reduced current characteristic of a three-phase induction motor during starting with a SIRIUS 3RW30 or 3RW40 soft starter

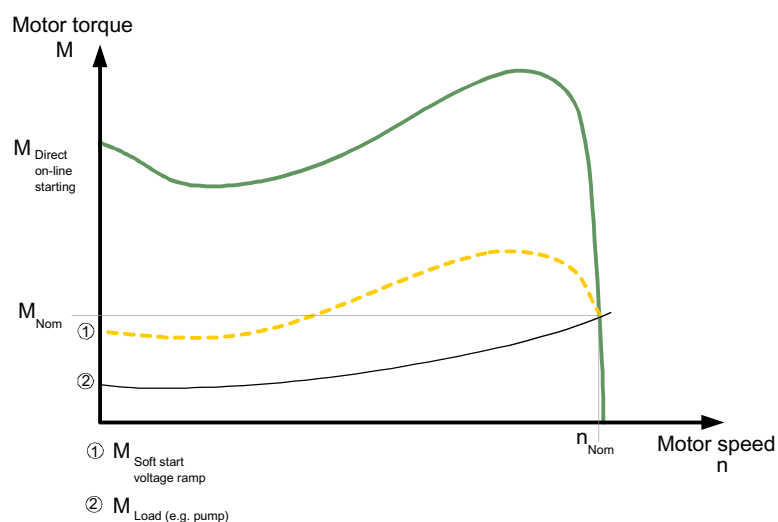

Figure 3-2 Reduced torque characteristic of a three-phase induction motor during starting with a SIRIUS 3RW30 or 3RW40 soft starter

Soft start /soft stop

This means that, since the motor voltage is controlled by the electronic soft starter during the startup process, the consumed starting current and the starting torque generated in the motor are also controlled.

The same principle is applied during the stop process. This ensures that the torque generated in the motor is gradually reduced, so that the application can stop smoothly (the soft stop function is only supported by the 3RW40).

The frequency remains constant during this process and corresponds to the mains frequency, in contrast to frequency controlled starting and stopping of a frequency converter.

Bypass mode

Once the motor has been started up correctly, the thyristors are subject to fully advanced control, meaning that the whole mains voltage is applied to the motor terminals. As the motor voltage does not have to be controlled during operation, the thyristors are bridged by integral bypass contacts that are rated for AC1 current. This minimizes the waste heat generated during uninterrupted duty (which is caused by the thyristor's power loss), and minimizes heating up of the switching device's environment.

The bypass contacts are protected by an integrated, electronic arc quenching system during operation. If they are opened in the event of a fault, e.g. if the control voltage is temporarily interrupted, mechanical vibrations occur, or the coil operating mechanism or the main contact spring has reached the end of its service life and is defective, the equipment is not damaged.

The diagram below shows the method of operation of the SIRIUS 3RW30 and 3RW40 soft starters:

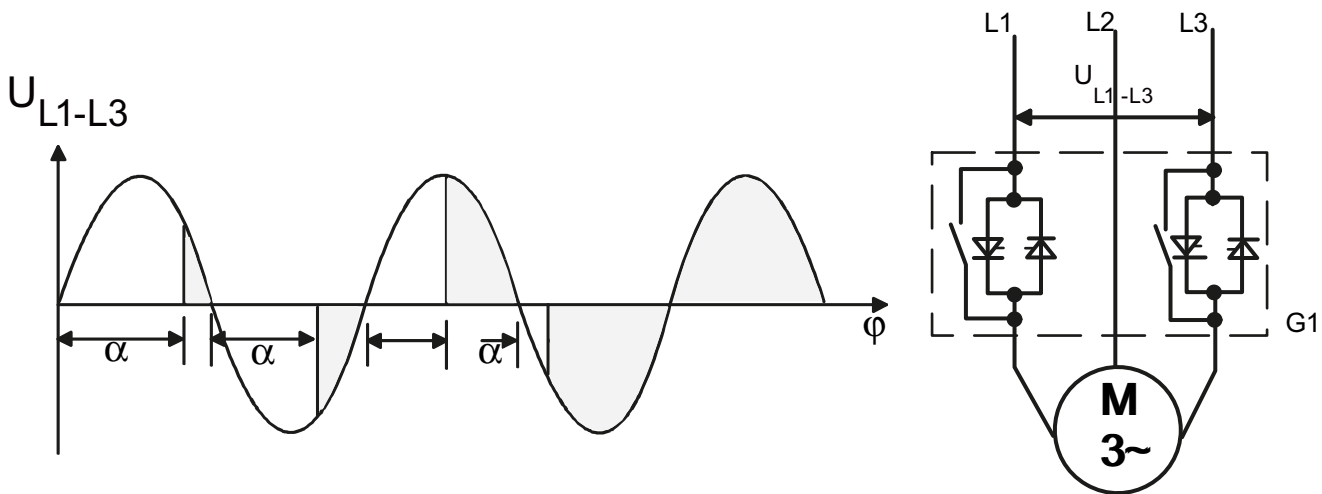

Figure 3-3 Phase angle control and schematic diagram of a two-phase controlled soft starter with integral bypass contacts

3.2.1 Method of operation of a two-phase controlled soft starter

A special method of operation is used for the SIRIUS 3RW30 and 3RW40 two-phase controlled soft starters based on SIEMENS' patented "polarity balancing" control principle.

Two-phase control

The SIRIUS 3RW30 and 3RW40 soft starters are two-phase controlled soft starters, in other words they are designed with two antiparallel thyristors in each of phases L1 and L3. Phase 2 is an uncontrolled phase, which is merely guided through the starter by a copper connection.

In a two-phase controlled soft starter, the current that results from the superimposition of the two controlled phases flows in the uncontrolled phase. The main advantages of two-phase control include the more compact size compared to a three-phase version and the lower hardware costs.

The occurrence of DC components, caused by the phase angle and the overlapping phase currents, is a negative physical effect of two-phase control during the startup process that can mean a louder noise is produced by the motor. The "polarity balancing" control principle was developed and patented by SIEMENS to prevent these DC components during starting.

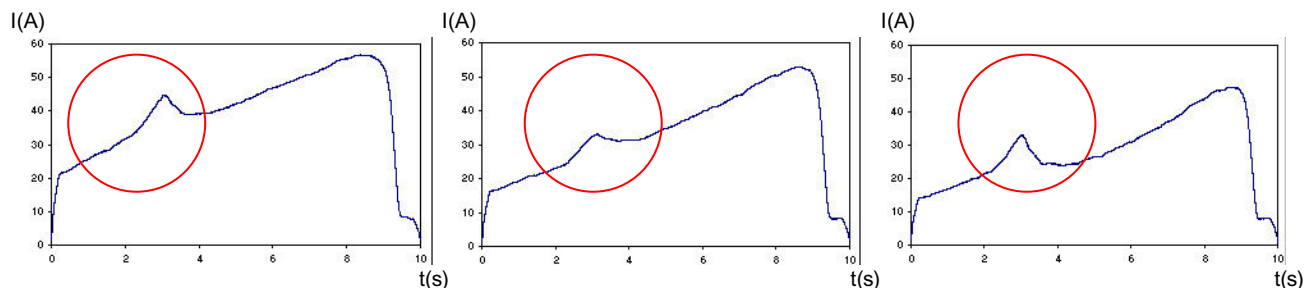

Figure 3-4 Current characteristic and occurrence of DC components in the three phases without "polarity balancing"

Polarity balancing

"Polarity balancing" effectively eliminates these DC components during the ramp-up phase. It allows the motor to be started up with a constant speed, torque, and current rise.

The acoustic quality of the startup process comes very close to that of a three-phase controlled startup. This is made possible by the continuous dynamic alignment and balancing of current half-waves with different polarities during the motor startup.

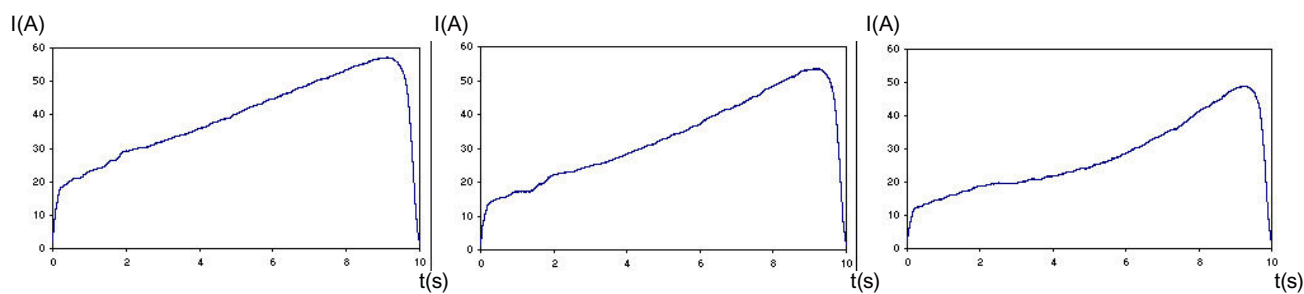

Figure 3-5 Current characteristic in the three phases without DC components thanks to "polarity balancing"

3.2.2 Starting current asymmetry

With two-phase control the starting current is asymmetrical for physical reasons, because the current in the uncontrolled phase is the sum of the currents in the two controlled phases.

This asymmetry can be as much as 30 to 40% during starting (current ratio: maximum deviation from mean value to mean value).

Even though this cannot be influenced, it is not critical in most applications. It could cause an insufficiently rated fuse to trip in the uncontrolled phase, for instance. For recommended fuse ratings, refer to the tables in the catalog (Page 143).

3.2 Functional principle of the SIRIUS 3RW30 and 3RW40 soft starters

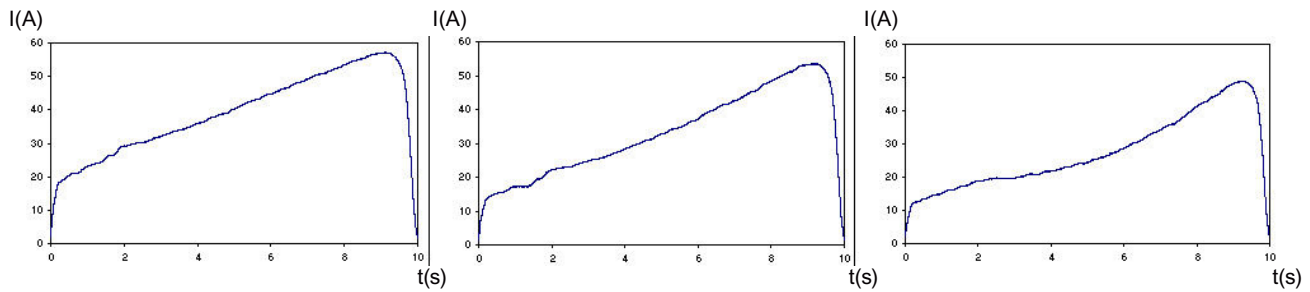

Figure 3-6 Starting current asymmetry

Note

If wye-delta starters are exchanged for soft starters in an existing system, you should check the fuse ratings in the feeder in order to avoid false tripping. This is particularly important in connection with heavy-duty starting or if the fuse that is installed has already been operated close to the thermal tripping limit with the wye-delta assembly.

All elements of the main circuit (such as fuses, motor starter protectors, and switching devices) must be dimensioned for direct starting and according to the on-site short-circuit conditions, and ordered separately.

For recommended fuse and motor starter protector ratings for the feeder with soft starter, refer to the catalog (Page 143).

3.2.3 Applications and use

Applications and selection criteria

The SIRIUS 3RW30 and 3RW40 soft starters represent a good alternative to direct or wye-delta starters.

The most important advantages are:

- Soft start
- Soft stop (3RW40 only)
- Uninterrupted switching without current peaks that place a heavy load on the system
- Simple installation and commissioning
- Compact, space-saving design

Applications

The typical applications include:

- Conveyor belts
- Roller conveyors
- Compressors

- Fans
- Pumps
- Hydraulic pumps
- Agitators
- Circular saws / band saws

Advantages

Conveyor belts and transport systems:

- Smooth starting
- Smooth stopping

Rotary pumps and piston pumps:

- No pressure surges
- Increased service life of the pipe system

Agitators and mixers:

- Reduced starting current

Fans:

- Protection for the gearbox and V belt

3.3 Accessories

3.3.1 Accessories for 3RW30 soft starters

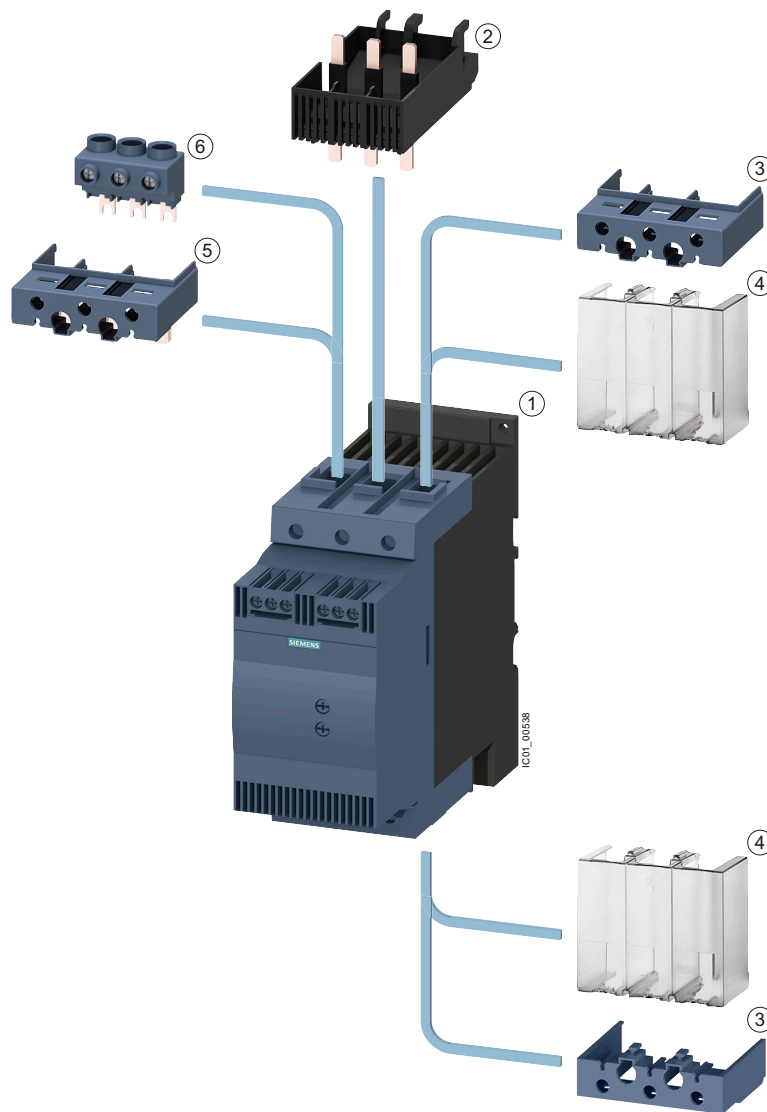

- ① 3RW30 soft starter
- ② Link module for circuit breaker/motor starter protector
- ③ Terminal cover for box terminals (S2, S3)
- ④ Terminal cover for cable lug connection and busbar connection (S3)
- ⑤ Auxiliary terminal (S3)
- ⑥ Infeed terminal (S00, S0)

3.3.2 Accessories for 3RW40 soft starters

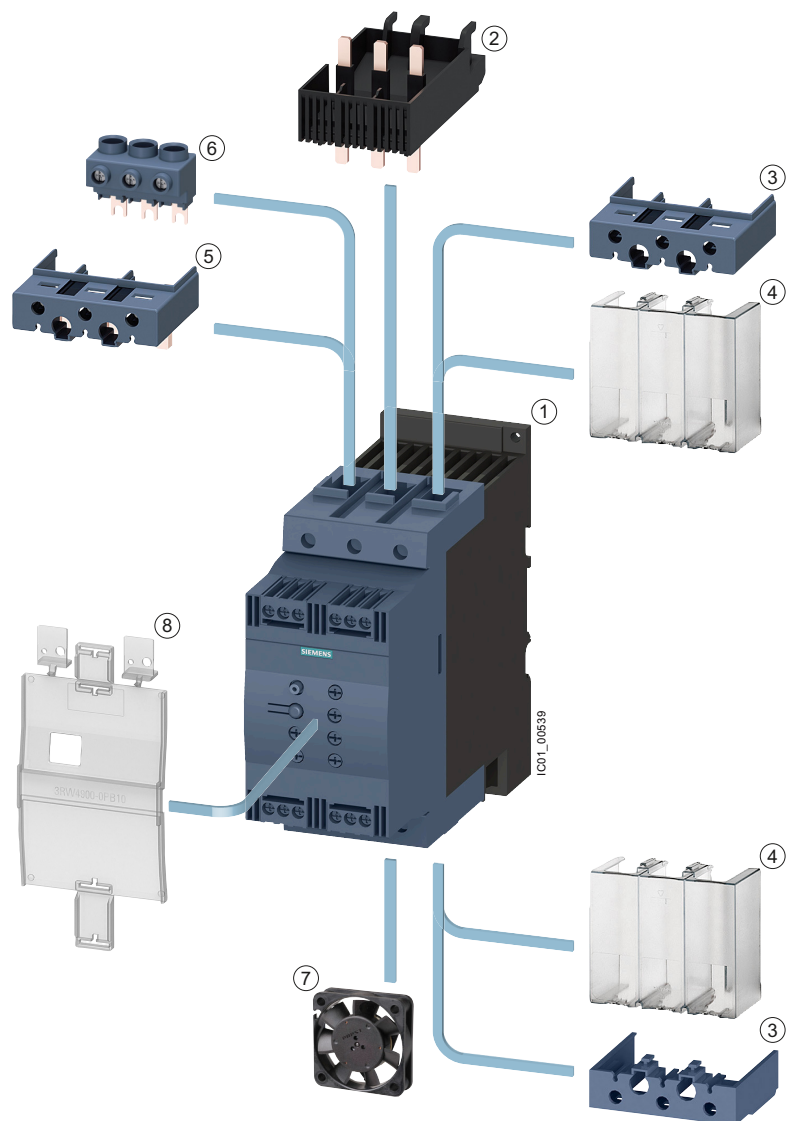

- ① 3RW40 soft starter
- ② Link module for circuit breaker/motor starter protector
- ③ Terminal cover for box terminals (S2, S3)
- ④ Terminal cover for cable lug connection and busbar connection (S3)
- ⑤ Auxiliary terminal (S3)
- ⑥ Infeed terminal (S0)
- ⑦ Fan
- ⑧ Sealable cover

Functions

4.1 Start modes

You can choose between different startup functions reflecting the wide range of applications and functionality of the SIRIUS 3RW30 and 3RW40 soft starters. The motor start can be optimally adapted to each particular application.

4.1.1 Voltage ramp

The SIRIUS 3RW30 and 3RW40 soft starters achieve soft starting by means of a voltage ramp. The motor terminal voltage is increased from a parameterizable starting voltage up to the mains voltage within a definable ramp-up time.

Starting voltage

The starting voltage determines the starting torque of the motor. A lower starting voltage results in a lower starting torque and a lower starting current. The starting voltage selected must be sufficiently high to ensure that motor starts up smoothly as soon as the start command is received by the soft starter.

Ramp time

The length of the set ramp time determines the time taken to increase the motor voltage from the parameterized starting voltage to the mains voltage. This influences the motor's acceleration torque, which drives the load during the ramp-up process. A longer ramp time results in a lower acceleration torque as the motor is started up. The startup is slower and smoother as a result. The ramp time should be long enough for the motor to reach its nominal speed. If the time selected is too short, in other words if the ramp time ends before the motor has started up successfully, a very high starting current that can even equal the direct starting current at the same speed occurs at this instant.

The SIRIUS 3RW40 soft starter limits the current to the value set with the current limiting potentiometer (refer to chapter Current limiting and ramp-up detection (3RW40 only) (Page 40)). As soon as the current limiting value is also reached, the voltage ramp or the ramp time is interrupted and the motor is started with the current limiting value until it has started up successfully. In this case, the motor ramp-up times may be longer than the maximum configurable 20 seconds ramp time (for further information about the maximum ramp-up times and switching frequencies, refer to chapter 3RW40 power electronics (Page 137) and following).

The SIRIUS 3RW40 soft starter has intrinsic device protection, current limiting, and ramp-up detection functions. These functions do not form part of the SIRIUS 3RW30 soft starter.

NOTICE

Risk of property damage

When using the 3RW30: Make sure the selected ramp time is longer than the actual motor ramp-up time. If not, the SIRIUS 3RW30 may be damaged because the internal bypass contacts close when the set ramp time elapses. If the motor has not finished starting up, an AC3 current that could damage the bypass contact system will flow.

When using the 3RW40: The 3RW40 has an integrated ramp-up detection function that prevents this operating state from occurring.

The maximum ramp time for the SIRIUS 3RW30 soft starter is 20 seconds. An appropriately dimensioned SIRIUS 3RW40 or SIRIUS 3RW5 soft starter should be chosen for startup processes with a motor ramp-up time > 20 seconds.

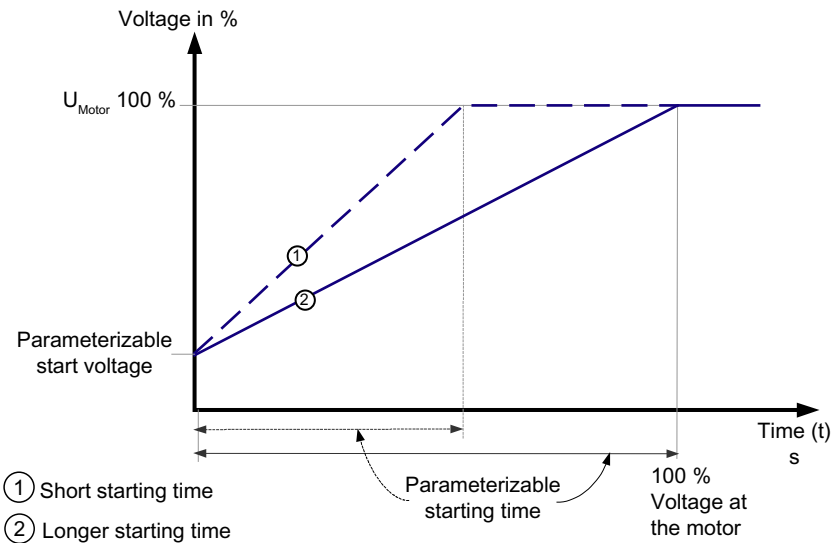

Figure 4-1 Principle of the voltage ramp

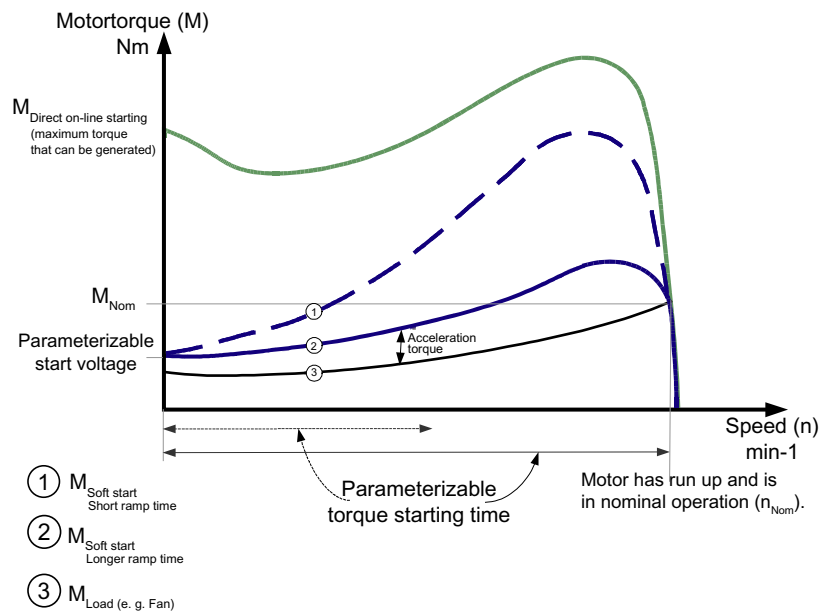

Figure 4-2 Principle of the voltage ramp for the torque characteristic

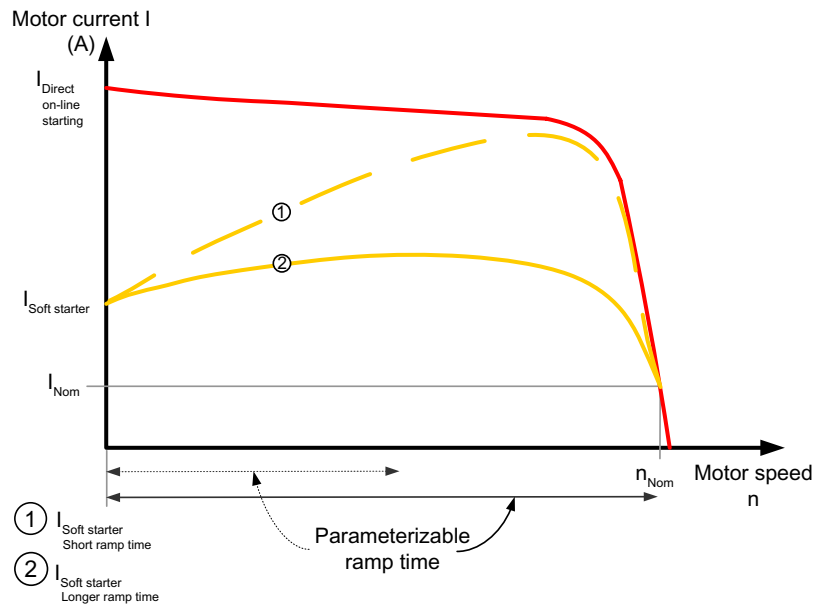

Figure 4-3 Principle of the voltage ramp for the starting current characteristic

Typical applications of the voltage ramp

The voltage ramp principle is valid for all applications, e.g. pumps, compressors, conveyor belts.

4.1.2 Current limiting and ramp-up detection (3RW40 only)

The SIRIUS 3RW40 soft starter measures the phase current (motor current) continuously with the help of integrated current transformers.

The motor current that flows during the startup process can be actively limited by means of the soft starter. The current limiting function takes priority over the voltage ramp function. As soon as a parameterizable current limit is reached, in other words, the voltage ramp is interrupted and the motor is started with the current limiting value until it has started up successfully. The current limiting function is always active with SIRIUS 3RW40 soft starters. If the current limiting potentiometer is set to clockwise stop, the starting current is limited to the maximum possible current (refer to chapter Setting the current limiting value (Page 113)).

Current limiting value

The current limiting value is set to the current required during starting as a factor of the rated motor current (refer to chapter Setting the current limiting value (Page 113)). Since the starting current is asymmetrical, the set current corresponds to the arithmetic mean value for the three phases.

Example

If the current limiting value is set to 100 A, the currents might be approx. 80 A in L1, 120 A in L2, and 100 A in L3 (refer to chapter Starting current asymmetry (Page 31)).

As soon as the selected current limiting value is reached, the motor voltage is reduced or controlled by the soft starter to prevent the current from exceeding the limit. The set current limiting value must be high enough to ensure that the torque generated in the motor is sufficient to accelerate the motor to nominal speed. Three to four times the value of the motor's rated operational current (I_e) can be assumed as typical here.

The current limiting function is always active because it is required by the intrinsic device protection. If the current limiting potentiometer is set to clockwise stop, the starting current is limited to the maximum possible current (refer to chapter Setting the current limiting value (Page 113)).

Ramp-up detection (3RW40 only)

The SIRIUS 3RW40 soft starter is equipped with an integrated ramp-up detection function. If it detects a motor startup, the motor voltage is immediately increased to 100% of the mains voltage. The internal bypass contacts close and the thyristors are bridged.

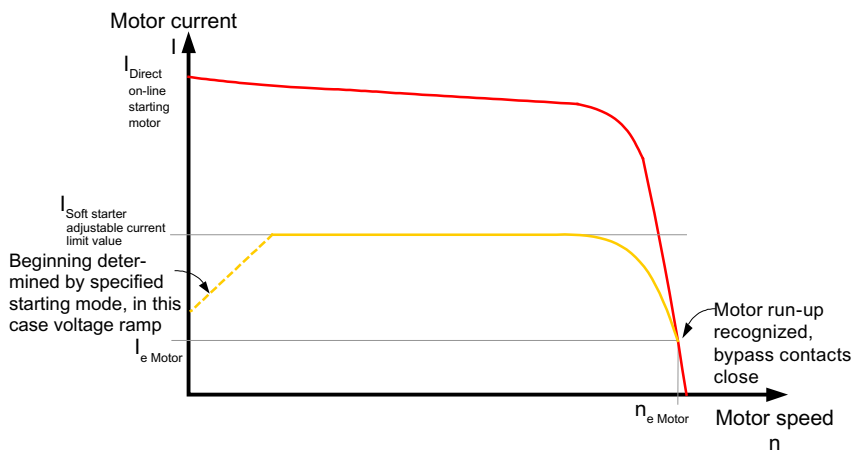

Figure 4-4 Current limiting with soft starter

Typical applications for current limiting

Current limiting is used for applications with large centrifugal masses (mass inertias) and therefore longer starting times, e.g. fans, circular saws etc.

4.2 Stop modes

You can choose between different stop modes reflecting the wide range of applications for SIRIUS soft starters. The motor stop can be optimally adapted to each particular application.

If a start command is issued during the stop process, the process is interrupted and the motor is started again with the set start mode.

Note

If you select "soft stop" (3RW40 only) as the stop mode, the feeder (soft starter, cables, feeder protective devices, and motor) may need to be dimensioned for higher values because the current exceeds the rated motor current during the stop process.

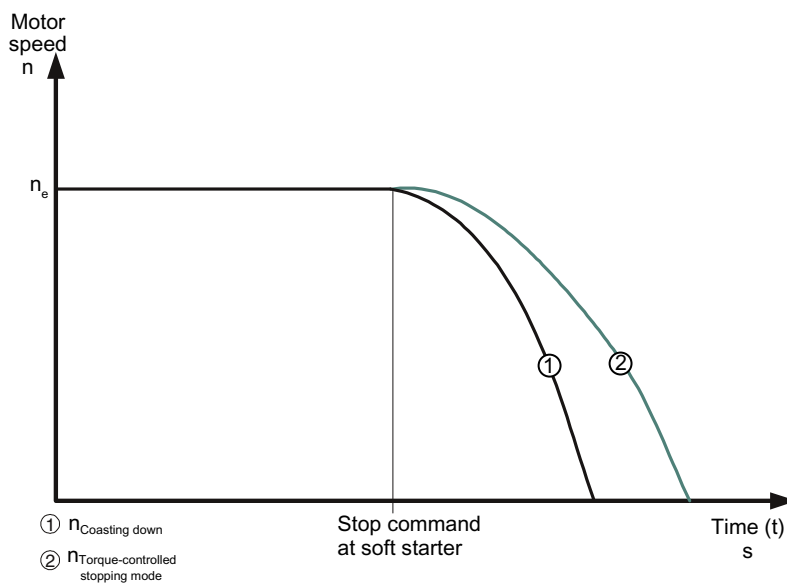

4.2.1 Stop without load (3RW30 and 3RW40)

"Stop without load" means the power supplied to the motor via the soft starter is interrupted when the ON command is removed from the starter. The motor coasts to a standstill, driven only by the mass inertia (centrifugal mass) of the rotor and load. This is also referred to as a natural stop. A large centrifugal mass means a longer stop time without load.

Typical applications for stop without load

Stop without load is used for loads that place no special demands on the startup characteristic, e.g. fans.

4.2.2 Soft stop (3RW40 only)

In "soft stop" mode, the natural stop process of the load is decelerated. The function is used when the load must be prevented from stopping abruptly. This is typically the case in applications with a low mass inertia or a high counter-torque.

Ramp-down time

The "Ramp-down time" potentiometer on the soft starter allows you to specify how long power should still be supplied to the motor after the ON command is removed. The torque generated in the motor is reduced by means of a voltage ramp function within this ramp-down time and the application stops smoothly.

If the motor is stopped abruptly in pump applications, as is normal with wye-delta or direct starting, for instance, water hammer can occur. Water hammer is caused by the sudden flow separation, leading to pressure fluctuations on the pump. It has the effect of producing noise and mechanical impacts on the pipelines as well as on any flaps and valves installed there.

Water hammer can be reduced compared to direct or wye-delta starting by using the SIRIUS 3RW40 soft starter. An optimum pump stop is achieved using a SIRIUS 3RW55 soft starter with an integrated pump stop function.

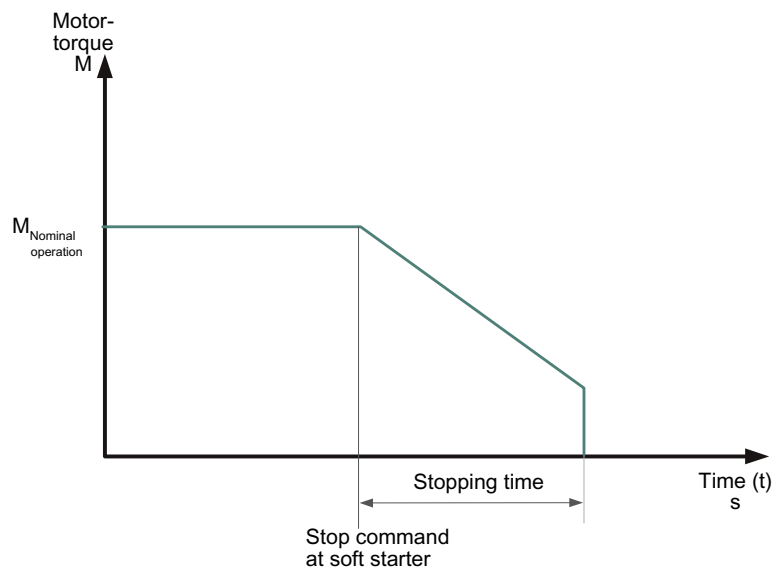

Typical applications for soft stop

Use soft stop for

- Pumps to reduce water hammer.
- Conveyor belts to prevent the conveyed product from tilting.

4.3 Motor protection / intrinsic device protection (3RW40 only)

Note

If the soft starter is disconnected because the motor overload protection or the intrinsic device protection trips, you must wait a defined cooling time (recovery time) prior to acknowledging the fault or starting the motor again. (Motor overload tripping time: 5 minutes, temperature sensor: after cooling,

intrinsic device protection tripping time:

- 30 seconds upon overload of the thyristors,
 - 60 seconds upon overload of the bypasses)
-

4.3.1 Motor protection function

The motor overload protection function is implemented on the basis of the winding temperature. This indicates whether the motor is overloaded or functioning in the normal operating range.

The winding temperature can either be calculated with the help of the integrated, electronic motor overload function or measured with a connected motor thermistor.

The two types of protection must be combined to achieve full motor protection. This combination is recommended to protect the motor optimally.

Note

Thermistor motor protection evaluation

The thermistor motor protection evaluation function is optionally available for the SIRIUS 3RW402 to 3RW404 soft starters in the 24 V AC/DC control voltage version.

Motor overload protection

The current flow during motor operation is measured by measuring the current with transformers integrated in the soft starter. The temperature rise in the winding is calculated based on the rated operational current set for the motor.

A trip is generated by the soft starter when the characteristic is reached, depending on the trip class (CLASS setting).

Trip class (electronic overload protection)

The trip class (CLASS) specifies the maximum time within which a protective device must trip from a cold state at $7.2 \times$ the rated operational current (motor protection to IEC 60947). The tripping characteristics represent this time as a function of the tripping current (refer to chapter Motor protection tripping characteristics for 3RW40 (with symmetry) (Page 143)). You can set different CLASS characteristics according to the startup class.

Note

The rating data of the soft starters refers to normal starting (CLASS 10). The starters may need to be calculated with a size allowance for heavy-duty starting ($>$ CLASS 10). You can only set a rated motor current that is lower than the soft starter rated current (for the permissible settings, refer to chapter Technical data (Page 125)).

Recovery time (motor overload protection)

A recovery time of 5 minutes, during which the motor cools down and cannot be restarted, starts if the thermal motor model is tripped.

Protection against voltage failure in the event of a fault

If the control supply voltage fails during a trip, the current tripping state of the thermal motor model and the current recovery time are stored in the soft starter. When the control supply voltage is restored, the current tripping state of the thermal motor model and the intrinsic device protection prior to the power failure are likewise automatically restored. If the control voltage is disconnected during operation (without a preceding fault trip), the starter is not protected against voltage failure.

Temperature sensor

Note

Temperature sensor

Temperature sensor evaluation is optionally available for the SIRIUS 3RW402 to 3RW404 soft starters in the 24 V AC/DC control voltage version.

This motor protection function measures the motor's stator winding temperature directly with the help of a sensor installed in the motor, in other words the motor must have a sensor wound into the stator winding.

You can choose between two different sensor types for the evaluation.

1. Type A PTC thermistors ("type A sensors") for connection to terminals T11/21 and T12
2. Thermoclick sensors for connection to terminals T11/21 and T22

The wiring and sensors are monitored for wire breakage and short-circuits.

Recovery time (thermistor motor protection)

If the thermistor motor protection is tripped, the soft starter cannot be restarted until the sensor installed in the motor has cooled down. The recovery time varies according to the temperature state of the sensor.

4.3.2 ATEX / IECEx for sizes S0 to S3

Safety instructions

 WARNING
Danger of death or serious injury.
The 3RW40 is not suitable for installation in hazardous areas. The device may only be used in a control cabinet with degree of protection IP4x. Appropriate measures (e.g. encapsulation) must be taken if it is to be installed in hazardous areas.

Note

Devices with ATEX and IECEx approval may be repaired only at the manufacturer's plant.

Have repairs of ATEX/IECEx devices carried out at the manufacturer's plant only. A repair that is not performed at the manufacturer's plant will result in loss of the ATEX/IECEx approval.

Parameterizing the motor protection functions (RESET setting)

Note that the "Auto RESET" setting is not permissible when operating motors in hazardous areas.

Explosion protection according to ATEX Directive 2014/34/EU and IECEx

The SIRIUS 3RW40 soft starter sizes S0 to S3 are suitable for starting explosion-proof motors with the "increased safety" type of protection Ex eb (type of protection / marking: II (2) GD Ex eb).

IECEx BVS 24.0016 X

[Ex eb Gb]

BVS 05 ATEX F 002 X

II (2) G [Ex eb Gb][Ex db Gb][Ex pxb Gb]

II (2) D [Ex tb Db][Ex pxb Db]

Wiring the fault output 95 96

Wire the fault output 95 96 to an upstream switching device in such a way that if a fault occurs, this device disconnects the feeder.

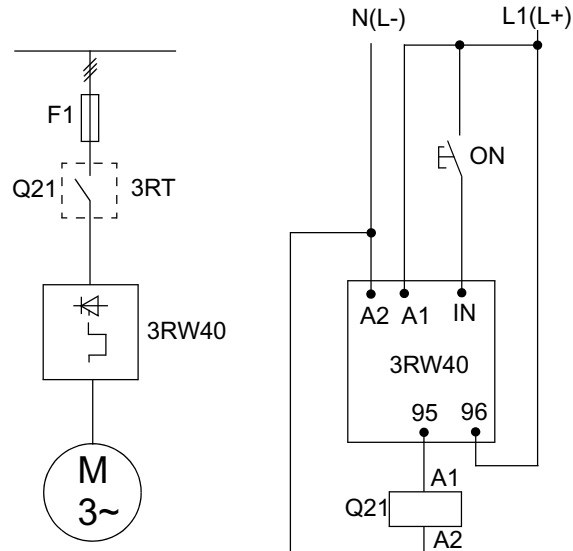

Figure 4-5 Wiring fault 3RW40 with 3RT

For more information, refer to the Operating Instructions 3ZX1012-0RW40-1CA1 (<https://support.industry.siemens.com/cs/ww/en/view/22809303>).

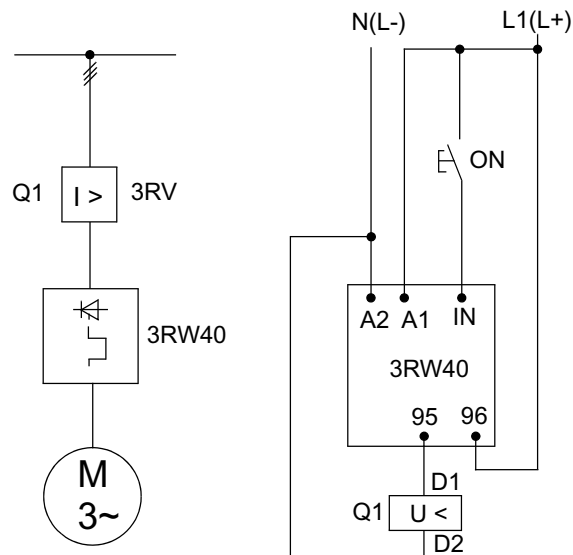

Figure 4-6 3RW40 wiring fault with 3RV

4.3.3 Intrinsic device protection (3RW40 only)

Thyristor protection (thermal)

SIRIUS 3RW40 soft starters are equipped with integrated intrinsic device protection to prevent thermal overloading of the thyristors.

This is achieved on the one hand by means of current measuring transformers in the three phases and on the other, by measuring the temperature with temperature sensors on the thyristor's heat sink.

If the fixed, internally set trip value is exceeded, the soft starter is automatically disconnected.

Recovery time (intrinsic device protection)

If the intrinsic device protection is tripped, the soft starter cannot be restarted until a recovery time of at least 30 seconds has elapsed upon overload of the thyristors and at least 60 seconds upon overload of the bypasses.

Thyristor protection (short-circuit)

SITOR semiconductor fuses must be connected upstream to protect the thyristors against short-circuits (e.g. in case of cable damage or an interturn fault in the motor; refer to chapter Soft starter assembly with type of coordination 2 (Page 72)). For the fuse selection tables, refer to the catalog (Page 11).

Protection against voltage failure (in the event of a fault)

If the control supply voltage fails during a trip, the current tripping state of the thermal intrinsic device protection model and the current recovery time are stored in the soft starter. When the control supply voltage is restored, the current tripping state of the thermal intrinsic device protection prior to the power failure are likewise automatically restored.

Note

If the control voltage is disconnected during operation (e.g. in "automatic mode"), the starter is not protected against voltage failure. You must wait five minutes between two starts to ensure that the motor protection and the intrinsic device protection are working correctly.

4.4 Functions of the RESET buttons

4.4.1 SIRIUS 3RW402, 3RW403 and 3RW404 soft starters

4.4.1.1 Setting the RESET MODE

RESET MODE button

By pressing the RESET MODE button, you define the reset procedure in case of a fault. This is indicated by the RESET MODE LED.

Note

On the SIRIUS 3RW402. soft starter, the RESET MODE button is located underneath the label (refer to chapter Operator controls, displays, and connections on the 3RW40 (Page 80)).

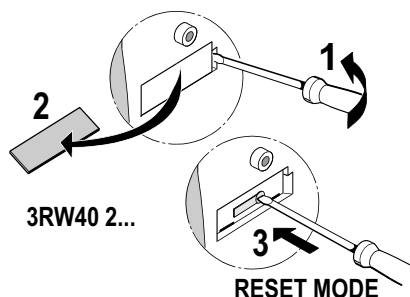

Auto RESET
Manual RESET
Remote RESET

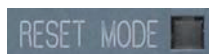

Yellow
Off (factory setting)
Green

4.4.1.2 Manual RESET

Manual RESET via RESET/TEST button (LED RESET MODE off)

You can reset a fault by pressing the RESET/TEST button.



4.4.1.3 Remote RESET

Remote RESET (LED RESET MODE green)

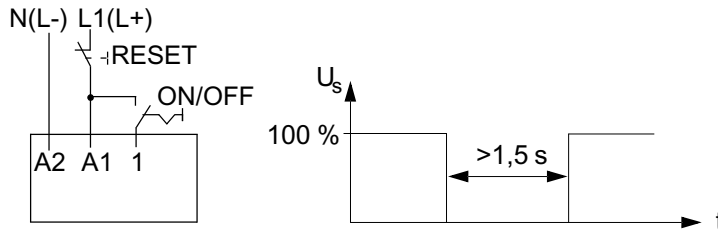

You can reset a pending error message by removing the control feed voltage for more than 1.5 s.

4.4.1.4 Auto RESET

Auto RESET (LED RESET MODE yellow)

If you set the RESET mode to AUTO, a fault is automatically reset.

- If the motor overload protection function trips: after 5 minutes
- On tripping the intrinsic device protection:
 - after 30 seconds upon overload of the thyristors,
 - after 60 seconds upon overload of the bypasses
- If the thermistor evaluation function trips: after the temperature sensor in the motor has cooled down

 WARNING
<p>Automatic restart Danger of death, serious injury, or property damage.</p> <p>The automatic reset mode (AUTO RESET) must not be used in applications where there is a risk of serious injury to persons or substantial damage to property if the motor starts up again unexpectedly. The start command (e.g. issued by a contact or the PLC) must be reset prior to issuing a RESET command because the motor attempts to restart again automatically following this RESET command if a start command is still present. This particularly applies if the motor protection has tripped. For safety reasons, you are advised to integrate the group fault output (terminals 95 and 96) in the controller.</p>

4.4.1.5 Acknowledging faults

For information on whether faults can be acknowledged, and on the corresponding LED and output contact states, refer to chapter Messages and diagnosis (Page 57).

4.4.2 Other functions of the RESET button

4.4.2.1 Motor protection trip test

You initiate a motor overload trip by pressing the RESET / TEST button for longer than five seconds. The SIRIUS 3RW40 soft starter is tripped by the fault signal at the OVERLOAD LED, the FAILURE / OVERLOAD contact 95-98 closes, and the motor that is connected and running is switched off.



RESET/TEST button of 3RW402, 3RW403 and 3RW404

4.4.2.2 Reparameterizing the ON / RUN output contact

For information about reparameterizing the output with the RESET / TEST button, refer to chapter Parameterizing the 3RW40 outputs (Page 122) .

4.4.3 Reset options for fault acknowledgement

Fault	RESET MODE		
	Manual RESET	Auto RESET	Remote RESET
Line fault (missing line voltage, phase failure, missing load)	+	—	+
I _e /CLASS setting not permissible	+	—	+
Asymmetry	+	—	+
Self-protection thyristor	+	+	+
Self-protection bypass	+	+	+
Motor protection	+	+	+
Thermistor motor protection	+	+	+
Supply voltage not permissible	Automatic	Automatic	Automatic

4.5 Functions of the inputs

4.5.1 Start input (terminal 1) on 3RW30 and 3RW402 to 3RW404

Rated control voltage is present at terminal A1 / A2: The startup process of the soft starter begins when a signal is present at terminal 1 (IN). The starter operates until the signal is removed again.

If a ramp-down time is parameterized (3RW40 only), a soft stop starts as soon as the signal is removed.

The potential of the signal at terminal 1 must correspond to the potential of the rated control voltage at terminal A1 / A2.



For recommended circuits, e.g. control by means of pushbuttons, contactor contacts, or a PLC, refer to chapter Typical circuit diagrams (Page 147).

4.5.2 Thermistor input / connection on 3RW402 to 3RW404

24 V AC/DC rated control voltage

After removing the copper jumper between T11/T21 and T22, you can connect and evaluate either a Klaxon thermistor integrated in the motor winding (at terminal T11/T21-T22) or a type A PTC (at terminal T11/T21-T12).

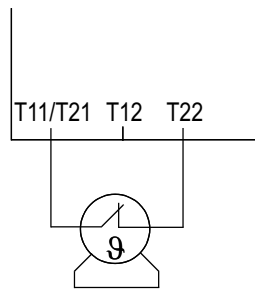
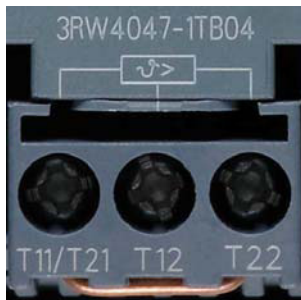

Klaxon

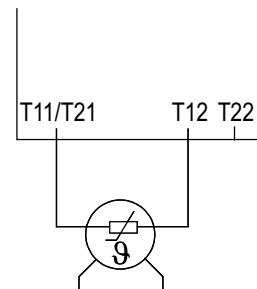

Type A PTC

4.6 Functions of the outputs

4.6.1 3RW30: Output terminal 13 / 14 ON

The potential-free output contact at terminal 13/14 (ON) closes if a signal is present at terminal 1 (IN); it remains closed until the start command is removed.

The output can be used, for instance, to control a line contactor connected upstream or to implement latching if you selected pushbutton control. For recommended circuits, refer to chapter Typical circuit diagrams (Page 147).

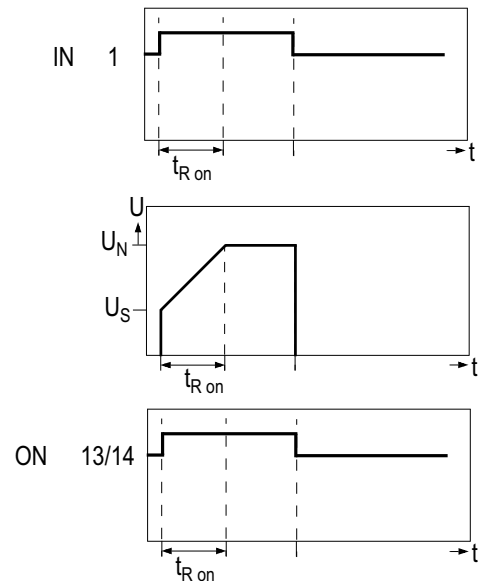

For a state diagram of the contact in the various operating states, refer to chapter Messages and diagnosis (Page 57).

4.6.2 3RW40: Output terminals 13 / 14 ON / RUN and 23 / 24 BYPASSED

ON

The potential-free output contact at terminal 13/14 (ON) closes if a signal is present at terminal 1 (IN); it remains closed until the start command is removed (factory default). The ON function can be used, for instance, as a latching contact if you selected pushbutton control.

Reparameterizing from ON to RUN

You can reparameterize the function of the ON output on the 3RW40 to RUN by simultaneously pressing the RESET TEST and RESET MODE buttons (refer to chapter Commissioning the 3RW40 (Page 108)).

4.6 Functions of the outputs

RUN

The RUN output remains closed as long as the motor is controlled by the soft starter, in other words during the startup phase, in bypass mode, and during the soft stop (if set). This output function can be used, for instance, if a line contactor connected upstream must be controlled by the soft starter, especially if the soft stop function is set.

BYPASSED

The BYPASSED function can be used, for instance, to indicate that the motor has started up successfully.

The BYPASSED output at terminal 23 / 24 closes as soon as the SIRIUS 3RW40 soft starter detects that the motor has started up (refer to chapter Ramp-up detection (Page 115)).

The integral bypass contacts simultaneously close and the thyristors are bridged. The integral bypass contacts and output 23 / 24 open again as soon as the start input IN is removed.

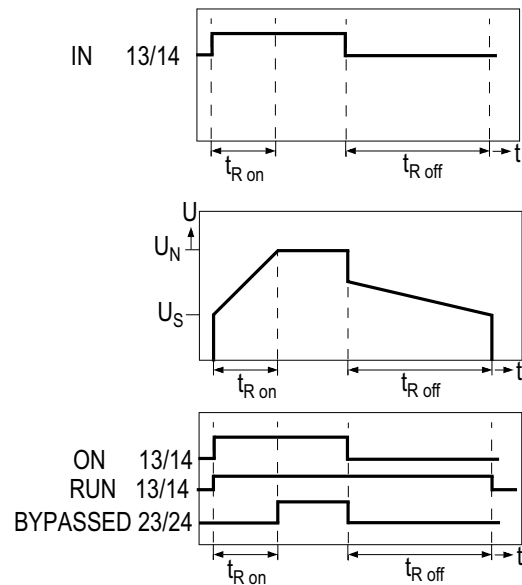
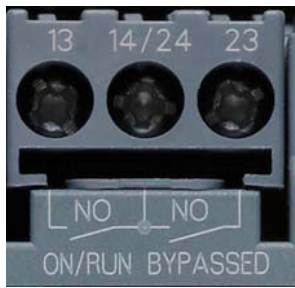

For a state diagram of the contacts and the LEDs in the various operating and fault states, refer to chapter Messages and diagnosis (Page 57).

For recommended circuits, refer to chapter Typical circuit diagrams (Page 147).

4.6.3 3RW40: Group fault output at terminal 95 / 96 / 98 OVERLOAD / FAILURE

If there is no rated control voltage or if a failure occurs, the potential-free FAILURE / OVERLOAD output is switched.



For recommended circuits, refer to chapter Typical circuit diagrams (Page 147).

For a state diagram of the contacts in the various fault and operating states, refer to chapter Messages and diagnosis (Page 57).

Messages and diagnosis

5.1 3RW30: LEDs

3RW30		3RW30 LED indicators		Aux. contact
		DEVICE (RD/GN/YE)	STATE/BYPASSED/FAILURE (GN/RD)	
		Soft starter		
$U_s = 0$		●	●	— / —
Operating state	IN			
Off	0	☀ GN	●	— / —
Startup	1	☀ GN	◐ GN	— / —
Bypassed	1	☀ GN	☀ GN	— / —
Fault				
Impermissible electronics supply voltage ¹⁾		●	☀ RD	— / —
Bypass overload ²⁾		☀ YE	☀ RD	— / —
- missing load voltage ¹⁾ - phase failure / missing load ¹⁾		☀ GN	☀ RD	— / —
Device error ³⁾		☀ RD	☀ RD	— / —

LED indications			GN	RD	YE
●	☀	◐	=	=	=
Off	On	Flashing	Green	Red	Yellow

1) The fault is automatically reset by an outgoing event. An automatic restart is initiated and the 3RW restarted if a start command is present at the input.

⚠ WARNING

Automatic restart
Danger of death, serious injury, or property damage.

If you do not want the motor to start automatically, you must integrate suitable additional components, e.g. phase failure or load monitoring devices, into the control and main circuits.

2) The fault can be acknowledged by removing the start command at the start input.

3) Switch off the control voltage, then switch it on again. If the fault is still present, contact your SIEMENS partner or Support Request (Page 15).

5.2 3RW30: Troubleshooting

Fault	Cause	Remedy
Impermissible electronics supply voltage	The control supply voltage does not correspond to the soft starter's rated voltage.	Check the control supply voltage; an incorrect control supply voltage could be caused by a power failure or a voltage dip.
Bypass overload	A current $> 3.5 \times I_e$ of the soft starter occurs for > 60 ms in bypass mode (e.g. because the motor is blocked).	Check the motor and load, and check the soft starter's dimensions.
Missing load voltage, phase failure / missing load	<p>Cause 1: Phase L1 / L2 / L3 is missing at the start of soft starting or fails / collapses when the motor is operating.</p> <p>A trip occurs if a phase failure is detected by the 3RW30 at the start of soft starting:</p> <ul style="list-style-type: none"> at the beginning of starting: tripping time $t > 0.5$ s in run-up or in bypass mode: phase failure not detected 	<p>Connect L1 / L2 / L3 or correct the voltage dip.</p> <p>Note:</p> <p>As soon as the motor is in run-up or bypass mode, these faults are no longer detected. The soft starter does not go to a fault state in these cases, and contact 13-14 remains closed.</p> <p>If the phase failure occurs in the uncontrolled phase, the response varies depending on whether the control voltage has a reference or connection to the AC network, or whether it is isolated:</p> <ul style="list-style-type: none"> If the control voltage is isolated, the phase failure of the uncontrolled phase will also be detected when the motor is switched off. With an On command, the 3RW30 goes immediately to a fault state, and contact 13 / 14 does not close. If the control voltage has a reference to the AC network, the phase failure of the uncontrolled phase is not detected, and with an On command, the soft starter attempts to start the motor. This can cause the motor to hum.
	<p>Cause 2: a motor that is not powerful enough is connected.</p> <p>A trip occurs if the current flowing through the 3RW30 soft starter at the start of soft starting is less than 10% of the rated operational current of the 3RW30, or less than 1 A.</p>	<p>Connect a motor with a higher rated operational current, or select a different soft starter.</p> <p>Note:</p> <p>As soon as the motor is in run-up or bypass mode, these faults are no longer detected. The soft starter does not go to a fault state in these cases, and contact 13-14 remains closed.</p>
	<p>Cause 3: Motor phase T1 / T2 / T3 is not connected.</p>	<p>Connect the motor properly (e.g. jumpers in the motor terminal box, repair switch closed etc.)</p>
Device error	Soft starter defective.	Contact your SIEMENS partner or Support Request (Page 15).

5.3 3RW402 / 3RW403 / 3RW404: LEDs

		LED statuses 3RW40				Auxiliary contacts			
		Soft starter		Motor protection		13 14 (ON)		24 23 (BYPASSED)	
3RW402 / 3RW403 / 3RW404		DEVICE (RD/GN/YE)	STATE / BYPASSED / FAILURE (GN/RD)	OVERLOAD (RD)	RESET MODE (YE/GN)	13 14 (ON)	13 14 (RUN)	24 23 (BYPASSED)	96 95 98 FAILURE / OVERLOAD
U _s = 0		●	●	●	●				
Operating state	IN								
Off	0	GN	●	●	●				
Start	1	GN	GN	●	●				
Bypassed	1	GN	GN	●	●				
Stop	0	GN	GN	●	●				
Warning									
I _e /class-setting impermissible ²⁾		GN	GN GN		●				
Start inhibited, device too warm (cooling time may vary accord. to thyristor temperature) ³⁾		YE	●	●	●				
Fault									
Impermissible electronics supply voltage ²⁾		●	RD	●	●				
Impermissible I _e / class setting and IN (0 -> 1) ²⁾		GN	RD		●				
Motor protection tripping Overload relay cooling time 5 min / Thermistor cooling time may vary according to motor temperature ¹⁾		GN	●		●				
Thermistor motor protection Wire break / short-circuit ^{1) 3)}		GN	●		●				
Thermal overload on device ³⁾ (cooling time > 30 s)		YE	RD	●	●				
- No load voltage - Phase failure, missing load ⁶⁾		GN	RD	●	●				
Device fault (cannot be acknowledged, device defective) ⁵⁾		RD	RD	●	●				
Test function									
Press TEST t>5s ⁴⁾		GN	●	RD	●				
RESET MODE (press to change)									
Manual reset		GN	●	●	●				
Auto reset		GN	●	●	YE				
Remote Reset		GN	●	●	GN				
Display of the LEDs					1) Optional, only 3RW402. to 3RW404. with 24 V AC/DC				
				GN = green	YE = yellow	RD = red	2) Is reset automatically with the right setting or by an outgoing event.		
						3) Must be acknowledged according to set reset mode			
						4) Motor protection trip test			
						5) Device faults cannot be acknowledged. Please contact your Siemens partner or Technical Assistance.			
						6) Can only be reset by manual or remote reset.			

 **WARNING**

Automatic restart

Can result in death, serious injury, or property damage.

The automatic reset mode (AUTO RESET) must not be used in applications where there is a risk of serious injury to persons or substantial damage to property if the motor starts up again unexpectedly. The start command (e.g. issued by a contact or the PLC) must be reset prior to issuing a RESET command because the motor attempts to restart again automatically following this RESET command if a start command is still present. This particularly applies if the motor protection has tripped. For safety reasons, you are advised to integrate the group fault output on the 3RW40 (terminals 95 and 96), or the signaling contact of the motor or miniature circuit breaker on all devices, in the controller.

5.4 3RW40: Troubleshooting

Warning	Cause	Remedy
Impermissible I_e /CLASS setting (control voltage present, no start command)	The rated operational current I_e set for the motor (control voltage present, no start command) exceeds the associated, maximum permissible setting current referred to the selected CLASS setting (chapter Motor current settings (Page 118)).	Check the rated operational current set for the motor, select a lower CLASS setting, or calculate the soft starter with a size allowance. As long as the 3RW40 is not controlled IN (0->1), this is only a status signal. However, it becomes a fault signal if the start command is applied.
Start inhibited, device too hot	The acknowledgment and the motor start are inhibited for a defined time by the inherent device protection following an overload trip, to allow the 3RW40 to cool down. Possible causes <ul style="list-style-type: none"> • Too many starts, • Motor starting time too long, • Ambient temperature in switching device's environment too high, • Minimum installation clearances not complied with. 	The device cannot be started until the temperature of the thyristor or the heat sink has cooled down enough to guarantee sufficient reserve for a successful startup. The time until restarting is allowed can vary but is a minimum of 30 s. Rectify the causes and, if necessary, retrofit the optional fan (for 3RW402. to 3RW404.).

Fault	Cause	Remedy
Impermissible electronics supply voltage:	The control supply voltage does not correspond to the soft starter's rated voltage.	Check the control supply voltage; could be caused by a power failure, voltage dip, or incorrect control supply voltage. Use a stabilized power supply unit if due to mains fluctuations.
Impermissible I_e /CLASS setting and IN (0->1) (control voltage present, IN start command changes from 0 to 1)	The rated operational current I_e set for the motor (control voltage present, start command present) exceeds the associated, maximum permissible setting current referred to the selected CLASS setting (chapter Motor current settings (Page 118)). For the maximum permissible settings, refer to chapter Technical data (Page 125).	Check the rated operational current set for the motor, select a lower CLASS setting, or calculate the soft starter with a size allowance.
Motor protection tripping Overload relay / thermistor:	The thermal motor model has tripped. After an overload trip, restarting is inhibited until the recovery time has elapsed. <ul style="list-style-type: none"> - Overload relay tripping time: 60 s - Thermistor tripping time: When the temperature sensor (thermistor) in the motor has cooled down. 	<ul style="list-style-type: none"> - Check whether the motor's rated operational current I_e is set correctly, or - Change the CLASS setting, or - Possibly reduce the switching frequency, or - Deactivate the motor protection (CLASS OFF), or - Check the motor and the application
Thermistor protection: wire breakage / short-circuit (optional for devices 3RW402. to 3RW404.):	Temperature sensor at terminals T11/T12/T22 is short-circuited or defective, a cable is not connected, or no sensor is connected.	Check the temperature sensor and the wiring

5.4 3RW40: Troubleshooting

Fault	Cause	Remedy
Thermal overload on the device:	<p>Overload trip of the thermal model for the power unit of the 3RW40</p> <p>Possible causes</p> <ul style="list-style-type: none"> • Too many starts, • Motor starting time too long, • Ambient temperature in switching device's environment too high, • Minimum installation clearances not complied with. 	<p>Wait until the device has cooled down again, possibly increase the current limiting value set for starting, or reduce the switching frequency (too many consecutive starts). If necessary, retrofit the optional fan (for 3RW402. to 3RW404.)</p> <p>Check the load and the motor, check whether the ambient temperature in the soft starter's environment is too high (de-rating above 40 °C, refer to chapter Technical data (Page 125)), comply with the minimum clearances.</p>
Missing load voltage, phase failure / missing load:	<p>Cause 1: Phase L1 / L2 / L3 is missing or fails / collapses when the motor is operating.</p> <p>A trip occurs if the current measured by the current transformers of the 3RW40 is less than 20% of the minimum rated motor current that can be set on the 3RW40 potentiometer:</p> <ul style="list-style-type: none"> • At starting/coasting down: tripping time $t > 1$ s • In bypass mode: tripping time $t > 5$ s 	Connect L1 / L2 / L3 or correct the voltage dip.
	<p>Cause 2: a motor that is not powerful enough is connected.</p> <p>A trip occurs if the current measured by the current transformers of the 3RW40 is less than 20% of the minimum rated motor current that can be set on the 3RW40 potentiometer, or less than 2 A.</p>	Set the rated operational current for the connected motor correctly on the 3RW40 potentiometer, or set it to the minimum.
	<p>Cause 3: Motor phase T1 / T2 / T3 is not connected.</p>	Connect the motor properly (e.g. jumpers in the motor terminal box, repair switch closed etc.)
Device error	Soft starter defective.	Contact your SIEMENS partner or Support Request (Page 15).

Application planning

6.1 Application examples

6.1.1 Roller conveyor application

Using the 3RW30 with roller conveyors

Roller conveyors are employed, for example, in parcel distribution systems for transporting parcels to and from individual workstations. For this purpose, the direction of rotation of the 11 kW / 15 hp motor that is used has to be adjustable in order for the conveyor to work in both directions.

The following requirements must be met by the roller conveyor:

- The roller conveyor has to start smoothly, to prevent damage to the transported goods due to slipping or tilting.
- The machine's wear and maintenance intervals should be minimized, which is why slippage of the belt drive during startup must be prevented.
- The high current load upon motor startup must be reduced by means of a voltage ramp.
- The feeder assembly should be as small as possible so as not to exceed the control cabinet's space capacity.

The SIRIUS 3RW30 soft starter offers the following advantages:

- The roller conveyor is rapidly accelerated to the nominal speed without torque surges thanks to the optimum setting of the voltage ramp during startup.
- The motor's starting current is reduced.
- Reversing operation of the conveyor belt is realized through contactor interconnection SIRIUS 3RA23 reversing contactor combinations are used.
- The feeder and the motor protection are implemented with SIRIUS 3RV motor starter protectors.
- The use of SIRIUS system components guarantees maximum wiring reductions and space savings.

6.1.2 Hydraulic pump application

Using the 3RW40 with hydraulic pumps

The SIRIUS 3RW40 is optimally suited for soft starting and stopping of hydraulic pumps. With a rating of 200 kW / 250 hp, this soft starter is used, for example, in the production of sheet parts to drive the presses.

The drives for hydraulic pumps must meet the following requirements:

- The motor's starting current has to be reduced to minimize the load on the higher-level mains transformer during startup.
- Integrated motor protection is called for to reduce wiring expenditure and space requirements in the control box.
- The hydraulic pump must be started and stopped in a soft manner to minimize the mechanical load on the drive and the pump caused by torque surges during starting and stopping.

The SIRIUS 3RW40 soft starter offers the following advantages:

- The settable current limiting of the SIRIUS 3RW40 limits the load on the mains transformer during the motor startup.
- Motor protection is ensured by the motor overload relay with settable tripping times integrated in the soft starter.
- The adjustable voltage ramp ensures that the hydraulic pump is started and stopped without torque surges.

Installation

7.1 Installing the soft starter

7.1.1 Unpacking

NOTICE

Do not lift the device by the cover

When unpacking the device, do not lift it by the cover, because this could lead to damage.

7.1.2 Permissible mounting position

3RW30

3RW40

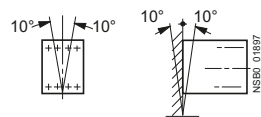

Vertical mounting

3RW402 ... 3RW404 (with optional auxiliary fan)

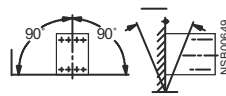

Horizontal mounting

Note

The permissible switching frequency values can vary according to the selected mounting position. For information about factors and how to determine the new switching frequency, refer to chapter Configuration (Page 83).

Note

An optional fan can be ordered for devices 3RW402 to 3RW404. The 3RW30 cannot be equipped with a fan.

7.1.3 Mounting dimensions, clearances, and assembly type

The minimum clearances from other devices must be complied with to ensure unobstructed cooling as well as the free supply and discharge of air to and from the heat sink.

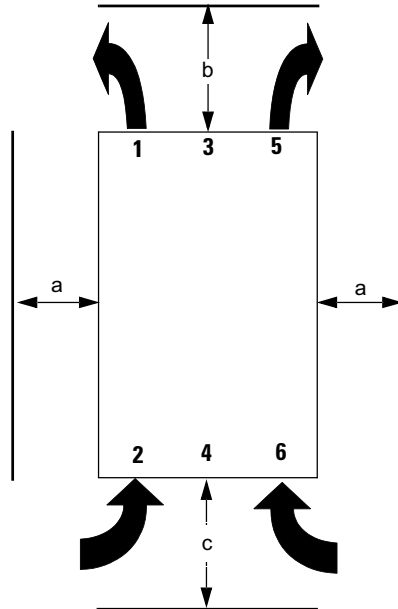

Figure 7-1 Clearances from other devices

Article No.	a (mm)	a (in)	b (mm)	b (in)	c (mm)	c (in)
3RW301./3RW302.	15	0.59	60	2.36	40	1.56
3RW303./3RW304	30	1.18	60	2.36	40	1.56
3RW402.	15	0.59	60	2.36	40	1.56
3RW403./3RW404.	30	1.18	60	2.36	40	1.56

Note

Allow sufficient clearances for the cooling air to circulate freely. The device is ventilated from bottom to top.

7.1.4 Assembly type: Standalone assembly, side-by-side assembly, direct mounting

Standalone assembly



The term "standalone assembly" is used if the clearances a / b / c described in chapter Mounting dimensions, clearances, and assembly type (Page 66) are complied with.

Side-by-side assembly



The term "side-by-side assembly" is used if the lateral clearance a described in chapter Mounting dimensions, clearances, and assembly type (Page 66) are not complied with, e.g. if several switching devices are assembled side by side.

Direct mounting



The term "direct mounting" is used if the top clearance b described in chapter Mounting dimensions, clearances, and assembly type (Page 66) is not complied with, e.g. if the soft starter is mounted directly on a motor starter protector (e.g. 3RV2) using a link module (e.g. 3RV29).

Note

The permissible switching frequency values can vary according to the selected assembly type. For information about factors and how to determine the new switching frequency, refer to chapter Configuration (Page 83).

7.1.5 Installation requirements

Degree of protection IP00

The SIRIUS 3RW30 / 3RW40 soft starters conform to the IP00 degree of protection.

The devices must be installed in control cabinets with IP4x degree of protection (pollution degree 2), taking account of the ambient conditions.

Make sure no liquids, dust, or conductive objects can get inside the soft starter. The soft starter produces waste heat (heat dissipation) while it is operating (refer to chapter Technical data (Page 125)).

NOTICE

Risk of material damage

Provide adequate cooling at the place of installation to prevent the switching device from overheating.

Installation / mounting

8.1 General information

General information

A motor feeder comprises a **disconnecter**, a **contact**, and a **motor** as a minimum.

Line protection against short-circuits must be implemented, together with overload protection for the line and motor.

Disconnecter

The isolating function with line protection against overload and short-circuits can be achieved with a motor starter protector or a fuse disconnecter, for instance. The motor overload protection function is integrated in the SIRIUS 3RW40 soft starter. The motor overload protection for the SIRIUS 3RW30 soft starter can be implemented with a motor circuit breaker, for instance, or using a motor overload relay in conjunction with a contactor (for the fuse and motor starter protector assignment, refer to the catalog (Page 11)).

Contact

The contact function is taken care of by the SIRIUS 3RW30 or 3RW40 soft starter.

DANGER

Hazardous voltage
Danger of death or serious injury.

If mains voltage is present at the input terminals of the soft starter, hazardous voltage may still be present at the soft starter output even if a start command has not been issued. This voltage must be isolated by means of a disconnecter (open isolating distance, e.g. with an open switch disconnecter) whenever work is carried out on the feeder (refer to chapter Five safety rules for work in or on electrical systems (Page 26)).

Note

All elements of the main circuit (such as fuses, motor starter protectors, and switching devices) must be dimensioned for direct starting and according to the on-site short-circuit conditions, and ordered separately.

For recommended fuse and motor starter protector ratings for the feeder with soft starter, refer to the catalog (Page 11).

8.2 General feeder assembly (type of coordination 1)

The SIRIUS 3RW30 or 3RW40 soft starter is connected into the motor feeder between the motor starter protector and the motor.

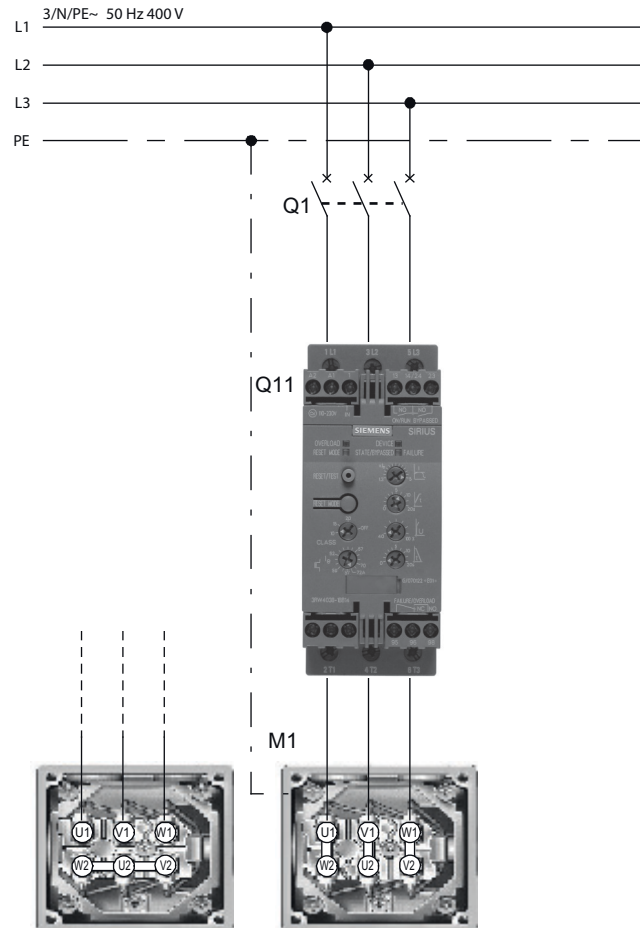

Figure 8-1 Block diagram of the SIRIUS 3RW40 soft starter

Note

For information on component configuration, refer to the catalog (Page 11).

8.3 Soft starter with line contactor (type of coordination 1)

If electrical isolation is specified, you can install a motor contactor between the soft starter and the motor starter protector.

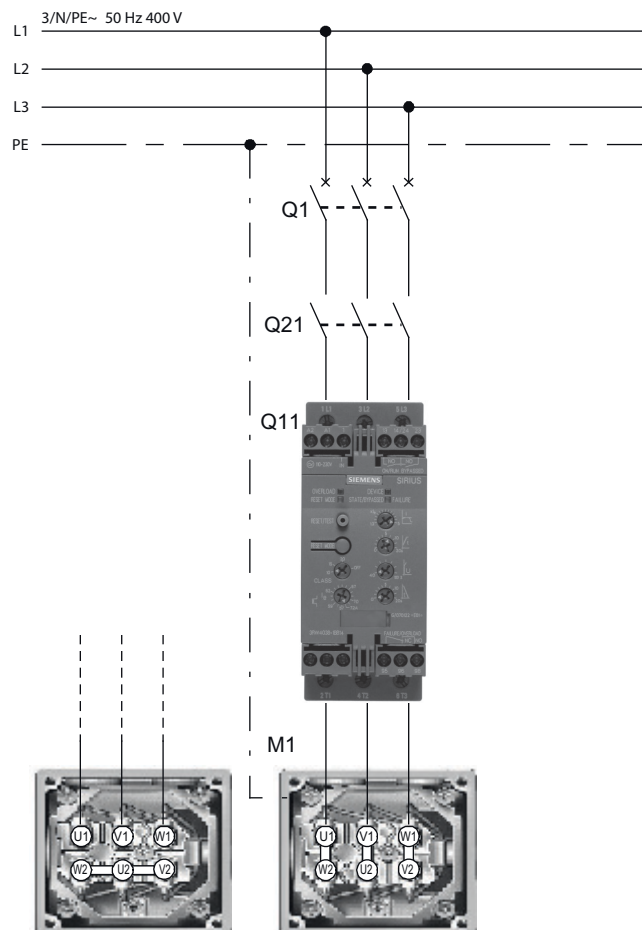

Figure 8-2 Block diagram of a feeder with an optional main / line contactor

Note

For information on component configuration, refer to the catalog (Page 11).

Note

If a main or line contactor is used, it should not be connected between the soft starter and the motor. The soft starter could otherwise indicate a "Missing load voltage" fault in case of a start command and delayed connection of the contactor.

8.4 Soft starter assembly with type of coordination 2

The SIRIUS 3RW40 soft starter has internal protection to prevent overloading of the thyristors. The SIRIUS 3RW30 soft starter has no internal protection to prevent overloading of the thyristors. The soft starter must always be dimensioned according to the duration of the startup process and the desired starting frequency. If the feeder of the SIRIUS 3RW30 or 3RW40 soft starter is assembled accordingly with the feeder components recommended in the catalog (Page 11) (e.g. motor starter protector or LV HRC fuse), type of coordination 1 is achieved. In order to achieve type of coordination 2, all thyristors must be additionally protected against short-circuits by means of special semiconductor fuses (e.g. SIEMENS SITOR). A short-circuit can occur, for instance, as a result of a defect in the motor windings or in the motor's power supply cable.

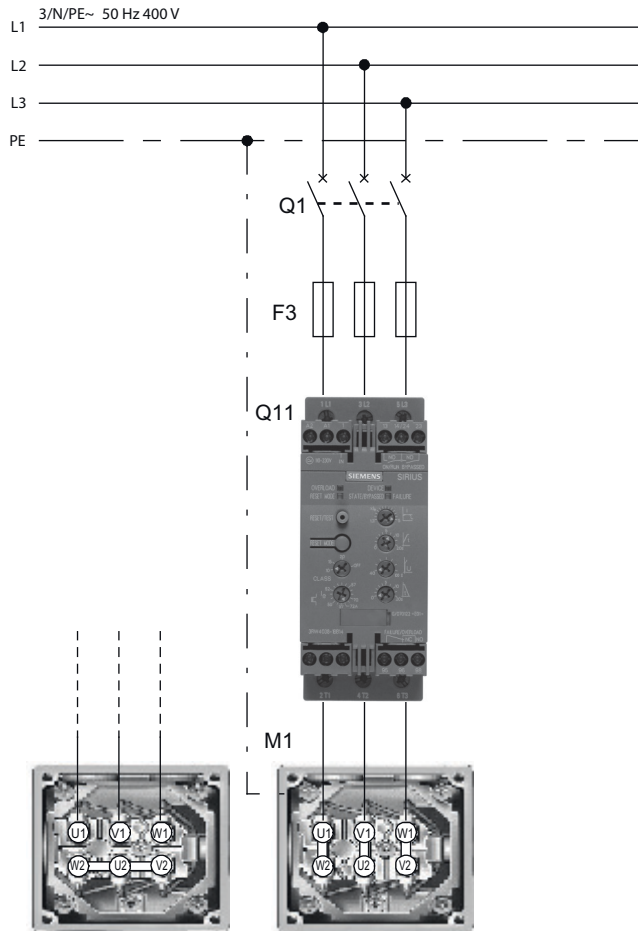

Figure 8-3 Block diagram of a feeder with semiconductor fuses

Note

For information on component configuration, refer to the catalog (Page 11).

Note**Minimum and maximum configuration of the semiconductor fuses**

The fuses for the minimum and maximum configuration are specified in the catalog (Page 11).

Minimum configuration: The fuse is optimized for the thyristor's I^2t value.

If the thyristor is cold (ambient temperature) and the startup process lasts a maximum of 20 s at 3.5 times the rated current of the device, the fuse does not trip.

Maximum configuration: The maximum current permitted for the thyristor can flow without the fuse tripping.

The maximum configuration is recommended for heavy-duty starting.

NOTICE**Risk of property damage**

Type of coordination 1 in accordance with IEC 60947-4-1:

The device is defective following a short-circuit failure and therefore unsuitable for further use (personnel and equipment must not be put at risk).

Type of coordination 2 in accordance with IEC 60947-4-1:

The device is suitable for further use following a short-circuit failure (personnel and equipment must not be put at risk).

The type of coordination only refers to soft starters in conjunction with the stipulated protective device (motor starter protector / fuse), not to additional components in the feeder.

8.5 Capacitors to improve the power factor

 **CAUTION**

Risk of property damage

No capacitors must be connected to the output terminals of the soft starter. If so, the soft starter will be damaged.

Active filters, e.g. for power factor correction, must not be operated parallel to the motor control device.

If capacitors are to be used to correct the power factor, they must be connected on the device's line side. If an isolating or main contactor is used together with the electronic soft starter, the capacitors must be disconnected from the soft starter when the contactor is open.

8.6 Maximum cable length

The cable between the soft starter and the motor must not be more than 300 m long (3RW30 and 3RW40).

The voltage drop due to the length of the cable to the motor may need to be considered when dimensioning the cable.

Longer cable lengths are permissible for SIRIUS 3RW5 soft starters.

Connecting

9.1 Electrical connection

9.1.1 Control and auxiliary terminals

The SIRIUS 3RW30 and 3RW40 soft starters can be supplied with two different connection technologies:

- Screw-type technology
- Spring-loaded technology

9.1.2 Main circuit connection

SIRIUS 3RW30 and 3RW40 soft starters up to the 55 kW / 75 hp size at 400 V / 480 V are designed with removable terminals at the main circuit connections.

Size 3RW301. to 3RW304.

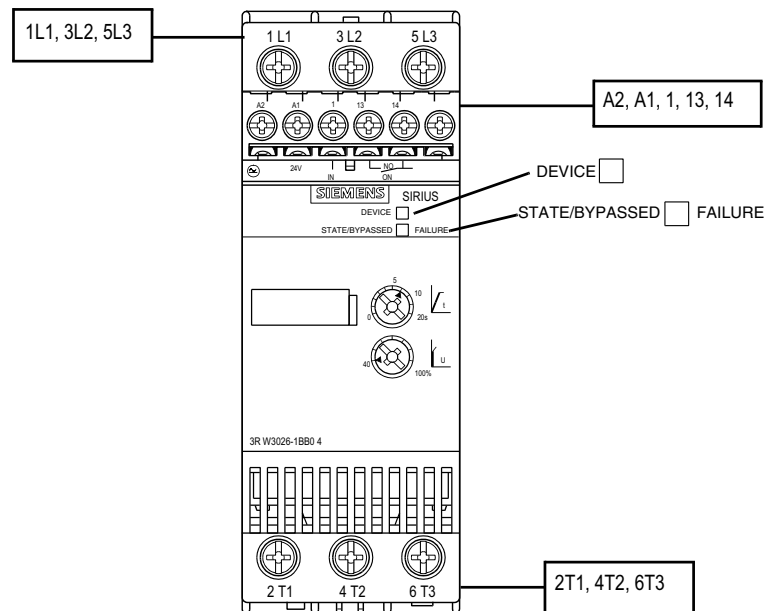

Size 3RW402. to 3RW404.

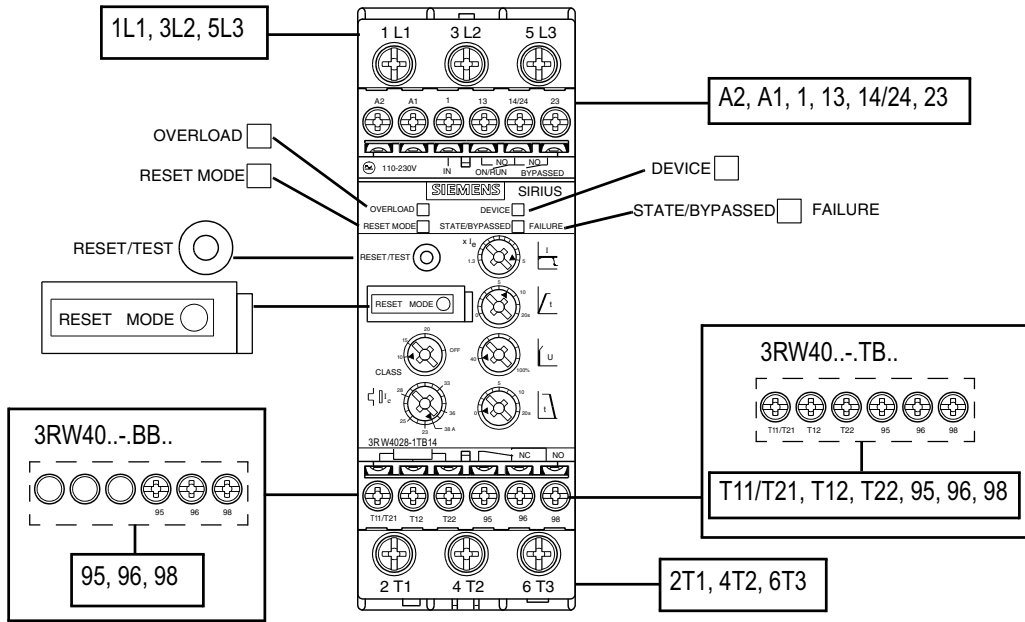

Operation

10.1 Operator controls, displays, and connections on the 3RW30

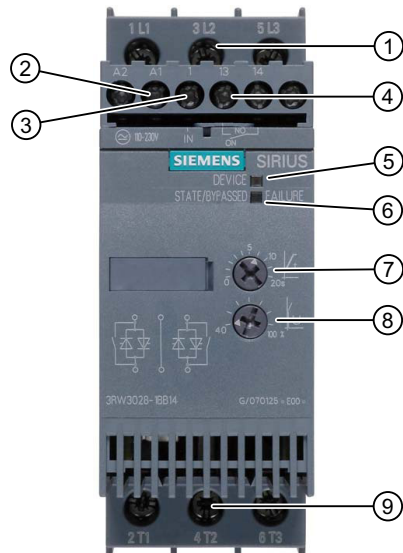

- 1 Operating voltage (three-phase mains voltage)
- 2 Control supply voltage
- 3 IN start input
- 4 ON output
- 5 DEVICE status LED
- 6 STATE / BYPASSED / FAILURE status LED
- 7 Ramp-up time
- 8 Starting voltage
- 9 Motor terminals

10.2 Operator controls, displays, and connections on the 3RW40

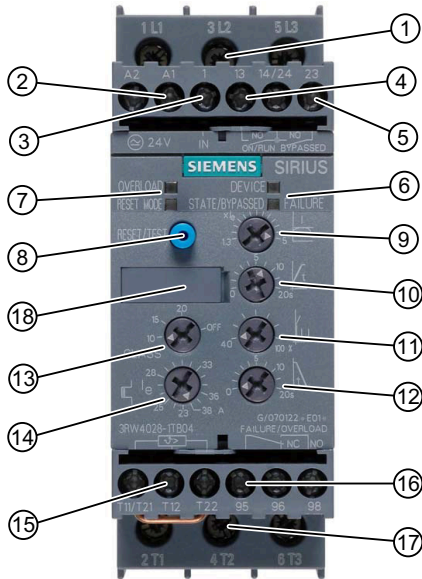

- 1 Operating voltage (three-phase mains voltage)
- 2 Control supply voltage
- 3 IN start input
- 4 ON / RUN output
- 5 BYPASSED output
- 6 DEVICE / STATE / BYPASSED / FAILURE status LEDs
- 7 OVERLOAD, RESET MODE status LEDs
- 8 TEST / RESET button
- 9 Current limiting
- 10 Ramp-up time
- 11 Starting voltage
- 12 Ramp-down time
- 13 Trip class
- 14 Motor current
- 15 Thermistor input (can be optionally ordered with 24 V AC/DC control voltage for 3RW402. to 3RW404. devices)
- 16 Fault output
- 17 Motor terminals
- 18 RESET MODE button (behind the label on the 3RW402., refer to the diagram below)

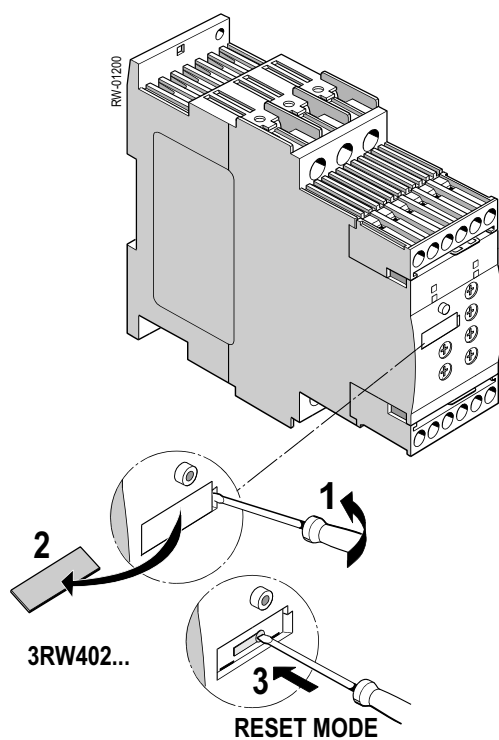

Figure 10-1 Button for setting RESET MODE behind the label

10.3 Effects on changing the potentiometer settings

Parameter change	Reaction / behavior Startup	Reaction / behavior Bypass operation	Reaction / behavior Run-down
Starting voltage	Effective at next start	Effective at next start	Effective at next start
Ramp-up time	Change effective immediately	Effective at next start	Change effective immediately
Limitation factor of current limitation	Change effective immediately	Effective at next start	Change effective immediately
Ramp-down time	Effective at next start	Effective at next shutdown	Change effective immediately in down ramp
Trip class	Change effective immediately	Change effective immediately	Change effective immediately
Rated motor current	Change effective immediately	Change effective immediately	Change effective immediately

Configuration

11.1 Configuration in general

The SIRIUS 3RW30 and 3RW40 electronic soft starters are designed for normal starting. A larger size may need to be selected for longer ramp-up times or a higher starting frequency.

An appropriately dimensioned SIRIUS 3RW40 or SIRIUS 3RW5 soft starter should be chosen for startup processes with a motor ramp-up time > 20 seconds.

The motor feeder between the soft starter and motor must not contain any capacitive elements (such as compensation systems). Active filters must not be operated in combination with soft starters.

All elements of the main circuit (such as fuses and switching devices) must be dimensioned for direct starting and according to the on-site short-circuit conditions, and ordered separately.

The harmonic component load of the starting current must be taken into consideration when selecting motor starter protectors (trip selection).

Note

Voltage dips generally occur in all start modes (direct starting, wye-delta starting, soft starting) when a three-phase motor is switched on. The infeed transformer must always be dimensioned so that the voltage dip at the motor startup remains within the permissible tolerance. If the infeed transformer is insufficiently dimensioned, the control voltage should be supplied from a separate circuit (independently of the main voltage) in order to prevent the voltage dip from disconnecting the 3RW.

Note

All elements of the main circuit (such as fuses, motor starter protectors, and switching devices) must be dimensioned for direct starting and according to the on-site short-circuit conditions, and ordered separately.

If wye-delta starters are exchanged for soft starters in an existing system, you should check the fuse ratings in the feeder in order to avoid false tripping. This is particularly important in connection with heavy-duty starting or if the fuse that is installed has already been operated close to the thermal tripping limit with the wye-delta assembly.

For recommended fuse and motor starter protector ratings for the feeder with soft starter, refer to the catalog (Page 11).

11.1.1 Configuration procedure

1. Select the correct starter

What application must be started and what functionality must be provided by the soft starter?

11.1 Configuration in general

Chapter Selecting the optimum soft starter (Page 84)

2. Take account of the startup class and the switching frequency

Chapters Startup class (Page 86) and Calculating the permissible switching frequency (Page 94)

3. Take account of a possible reduction in the soft starter's rated data due to the ambient conditions and the type of assembly.

Chapter Reducing the rated data (Page 90)

11.1.2 Selecting the optimum soft starter

Selection aid

You can choose the optimum starter from the soft starter types available based on the intended application or the required functionality.

Normal starting (CLASS 10) applications	3RW30	3RW40	3RW55
Pump	+	+	+
Pump with special stop (against water hammer)	-	-	+
Heat pump	+	+	+
Hydraulic pump	x	+	+
Press	x	+	+
Conveyor belt	x	+	+
Roller conveyor	x	+	+
Conveyor worm	x	+	+
Escalator	-	+	+
Piston compressor	-	+	+
Screw compressor	-	+	+
Small fan ¹⁾	-	+	+
Centrifugal blower	-	+	+
Bow thruster	-	+	+

+ Recommended soft starter

x Possible soft starter

1) Small fan: Mass inertia (centrifugal mass) of fan < 10 x mass inertia of motor

Heavy-duty starting (CLASS 20) applications	3RW30	3RW40	3RW55
Agitator	-	x	+
Extruder	-	x	+

Heavy-duty starting (CLASS 20) applications	3RW30	3RW40	3RW55
Turning machine	-	x	+
Milling machine	-	x	+

+ Recommended soft starter

x Possible soft starter

Ultra-heavy-duty starting (CLASS 30) applications	3RW30	3RW40	3RW55
Large fan ²⁾	-	-	+
Circular saw / band saw	-	-	+
Centrifuge	-	-	+
Mill	-	-	+
Crusher	-	-	+

+ Recommended soft starter

2) Large fan: Mass inertia (centrifugal mass) of fan ≥ 10 x mass inertia of motor

Soft starter functions	3RW30	3RW40	3RW55
Soft start function	+	+	+
Soft stop function	-	+	+
Integrated intrinsic device protection	-	+	+
Integrated electronic motor overload protection	-	+	+
Settable current limiting	-	+	+
Special pump stop function	-	-	+
Braking when coasting down	-	-	+
Settable breakaway torque	-	-	+
Communication via PROFIBUS (optional)	-	-	+
External operation and indication display (optional)	-	-	+
Soft Starter ES parameterization software	-	-	+
Special functions, e.g. measured values, display languages etc.	-	-	+
Motor overload protection acc. to ATEX	-	+	-

+ Recommended soft starter

Note

SIRIUS 3RW55 soft starter

For more information about the SIRIUS soft starter, refer to the 3RW55 Device Manual. You can download (<https://support.industry.siemens.com/cs/ww/en/view/109753752>) the manual free of charge.

11.2 Startup class

To achieve the optimum soft starter design, it is important to know and take into account the starting time (startup class) of the application. Long starting times mean a higher thermal load on the thyristors of the soft starter. An appropriately dimensioned SIRIUS 3RW40 or SIRIUS 3RW55 soft starter should be chosen for startup processes with a motor ramp-up time > 20 seconds. The maximum permissible starting time for SIRIUS 3RW30 soft starters is 20 seconds. SIRIUS soft starters are designed for continuous operation with normal starting (CLASS 10), an ambient temperature of 40 °C, and a defined switching frequency (refer to chapter Technical data (Page 125)). If other data applies, the starters may need to be calculated with a size allowance.

NOTICE

Risk of property damage

When using the 3RW30: Make sure the selected ramp time is longer than the actual motor run-up time. If not, the SIRIUS 3RW30 may be damaged because the internal bypass contacts close when the set ramp time elapses. If the motor has not finished starting up, an AC3 current that could damage the bypass contact system will flow.

When using the 3RW40: The 3RW40 has an integrated ramp-up detection function that prevents this operating state from occurring.

Selection criteria

Note

You must select the size of your SIRIUS soft starters according to the rated motor current (rated current_{soft starter} ≥ rated motor current).

11.2.1 Application examples for normal starting (CLASS 10) with 3RW30 and 3RW40

Recommended basic parameter settings

Assuming the conditions and constraints indicated below apply, the size of the soft starters can be equivalent to the motor rating for a normal starting characteristic (CLASS 10).

You can find a suitable soft starter for the required motor rating based on the required startup class in chapter Technical data (Page 125).

For typical applications where normal starting applies as well as recommended parameter settings for the soft starter, refer to the table below.

Normal starting (CLASS 10)

The soft starter rating can be equivalent to the motor rating.

Application	Conveyor belt	Roller conveyor	Compressor	Small fan ¹⁾	Pump	Heat / hydraulic pump
Start parameters						
• Voltage ramp and current limiting						
- Starting voltage	% 70	60	50	40	40	40
- Ramp-up time	s 10	10	10	10	10	10
- Current limiting value (3RW40)	off (max / 5 x I _M)	off (max / 5 x I _M)	4 x I _M	4 x I _M	4 x I _M	4 x I _M
Stop mode	Soft stop (3RW40 only)	Soft stop (3RW40 only)	Stop without load	Stop without load	Soft stop (3RW40 only)	Stop without load

1) Small fan: Mass inertia (centrifugal mass) of fan < 10 x mass inertia of motor

General conditions and constraints	
CLASS 10 (normal starting)	
3RW30: Maximum starting time 3 s, 300 % starting current, 20 starts / hour	
3RW40: Maximum starting time 10 s, 300% current limiting, 5 starts / hour	
ON time	30%
Standalone assembly	
Installation altitude	Max. 1000 m / 3280 ft
Ambient temperature kW	40 °C / 104 °F

11.2.2 Application examples for heavy-duty starting (CLASS 20): 3RW40 only

Recommended basic parameter settings

Assuming the conditions and constraints indicated below apply, the soft starter size must be at least one power class higher than the motor rating for heavy-duty starting (CLASS 20).

You can find a suitable soft starter for the required motor rating based on the required startup class in chapter Technical data (Page 125).

For typical applications where heavy-duty starting can apply as well as recommended parameter settings for the soft starter, refer to the table below.

Heavy-duty starting (CLASS 20)

The soft starter must be at least one power class larger than the motor rating.

Application	Agitator	Extruder	Milling machine
Start parameters			
• Voltage ramp and current limiting			
- Starting voltage	% 40	70	40
- Ramp-up time	s 20	10	20
- Current limiting value (3RW40)	4 x I _M	off (max / 5 x I _M)	4 x I _M
Stop mode	Stop without load	Stop without load	Stop without load

General conditions and constraints	
CLASS 20 (heavy-duty starting)	
3RW402. / 3RW403. / 3RW404.	Maximum starting time 20 s, 300% current limiting, max. 5 starts / hour
ON time	30%
Standalone assembly	
Installation altitude	Max. 1000 m / 3280 ft
Ambient temperature kW	40 °C / 104 °F

Note

The settings and device dimensions indicated in these tables are examples only; they are merely provided for information purposes and are not binding. The actual settings depend on the application and must be optimized when the equipment is commissioned.

If other conditions and constraints apply, either refer to the chapter Technical data (Page 125) or check your requirements and selection with Support Request (Page 15).

11.3 ON time and switching frequency

Based on the rated motor current and the startup class, the SIRIUS 3RW30 and 3RW40 soft starters are dimensioned for a maximum permissible switching frequency in combination with a relative ON time (refer to chapter Technical data (Page 125)). If these values are exceeded, a larger soft starter may have to be selected.

ON time

The relative ON time in % is the ratio between the load duration and the cycle duration for loads that are frequently switched on and off.

The ON time (OT) can be calculated using the following formula:

$$OT = \frac{t_s + t_b}{t_s + t_b + t_p}$$

where:

OT = ON time [%]

t_s = starting time [s]

t_b = operating time [s] (incl. configured ramp-down time)

t_p = idle time [s]

The following diagram illustrates this process.

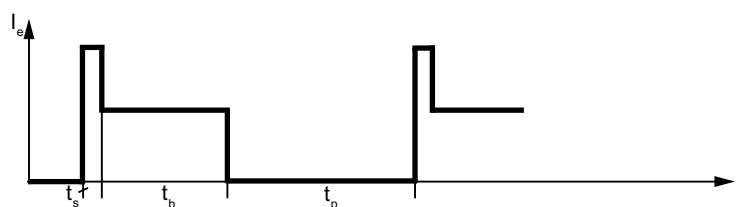

Figure 11-1 ON time

Switching frequency

The maximum permissible switching frequency must not be exceeded because the devices could be damaged due to thermal overloading.

Optional additional fan

The switching frequency of the 3RW402. to 3RW404. soft starters can be increased by installing an optional additional fan. For information about factors and how to determine the maximum switching frequency if an additional fan is installed, refer to chapter Calculating the permissible switching frequency (Page 94).

11.4 Reducing the rated data

You can reduce the rated data of the SIRIUS 3RW30 and 3RW40 soft starters if

- The installation altitude is higher than 1000 m.
- The ambient temperature in the switching device's environment exceeds 40 °C.
- The lateral clearances described earlier are not complied with, e.g. side-by-side assembly or direct mounting of other switching devices (assembly type).
- The vertical mounting position is not complied with.

11.5 Dimensioning of soft starters for motors with high starting current conditions

When using motors with high starting current conditions (typically $I/I_e \geq 8$), overdimensioning of the 3RW40 soft starter can be necessary. For this application case, we recommend 3RW40 soft starters with product version E07 or higher (for 3RW40 sizes S0, S2, S3). These 3RW40 devices make it possible to select the set value for current limiting sufficiently high for a successful motor start (refer to chapter Setting the current limiting value (Page 113)).

For dimensioning soft starters for motors with high starting current conditions (typically $I/I_e > 8$), refer to Siemens Support Request (Page 15).

11.6 Installation altitude and ambient temperature

Installation altitude

The permissible installation altitude must not be higher than 5000 m above sea level (higher than 5000 m on request).

If the installation altitude exceeds 1000 m, the rated operational current must be reduced for thermal reasons.

If the installation altitude exceeds 2000 m, the rated voltage must also be reduced owing to the restricted dielectric strength. A maximum permissible rated voltage of 460 V applies at installation altitudes between 2000 m and 5000 m above sea level.

The following diagram shows the reduction in the rated device current as a function of the installation altitude:

The rated operational current I_e must be reduced at altitudes higher than 1000 m above sea level.

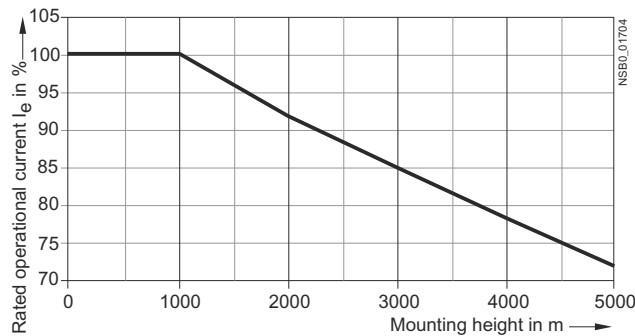

Figure 11-2 Reduction as a function of the installation altitude

Ambient temperature

The maximum permissible ambient temperature of the soft starter must not exceed 60 °C.

SIRIUS 3RW30 and 3RW40 soft starters are designed for operation with nominal current at an ambient temperature of 40 °C. If this temperature is exceeded, e.g. owing to an impermissible temperature rise in the control cabinet, other loads, or a general increase in the ambient temperature, the resulting deterioration in the soft starter's performance must be taken into account when the device is dimensioned (refer to chapter Technical data (Page 125)).

NOTICE

Risk of material damage

The soft starter may be damaged if the maximum installation altitude (5000 m above sea level) or an ambient temperature of 60 °C is ignored.

Mounting position, assembly type

The mounting position and assembly type (refer to chapter Installing the soft starter (Page 65)) can influence the soft starter's permissible switching frequency. Refer to chapter Calculating the permissible switching frequency (Page 94) for the permissible mounting and assembly combinations as well as the resulting factors for the soft starter switching frequencies.

11.7 Calculating the permissible switching frequency

11.7 Calculating the permissible switching frequency

11.7.1 Table of permissible assembly combinations with switching frequency factors

The factors indicated in the table refer to the switching frequency (starts / hour) as specified in chapter Technical data (Page 125).

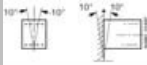
		 Vertical mounting									
Graph	Assembly type	3RW30				3RW40			3RW40 + optional fan		
		3RW301*	3RW302*	3RW303*	3RW304*	3RW402*	3RW403*	3RW404*	3RW402*	3RW403*	3RW404*
A	Standalone assembly	1.0				1.0			1.6	2.0	2.8
B	Side-by-side assembly	0.7	0.1	0.3		0.1	0.3		1.6	2.0	2.8
C	Standalone assembly	0.5		0.8		0.5	0.8		1.6	2.0	
D	Side-by-side assembly	0.3	-	-		-			1.6	1.8	

		 Horizontal mounting			
Graph	Assembly type	3RW30/40	3RW40 + optional fan		
			3RW402*	3RW403*	3RW404*
A	Standalone assembly	-	1.6	2.0	2.8
B	Side-by-side assembly	-	1.6	2.0	2.8
C	Standalone assembly	-	1.6	2.0	
D	Side-by-side assembly	-	1.4	1.8	

Standard switching frequency
High switching frequency (fan required)
Reduced switching frequency
Assembly type not permitted
Assembly type not tested

11.7 Calculating the permissible switching frequency

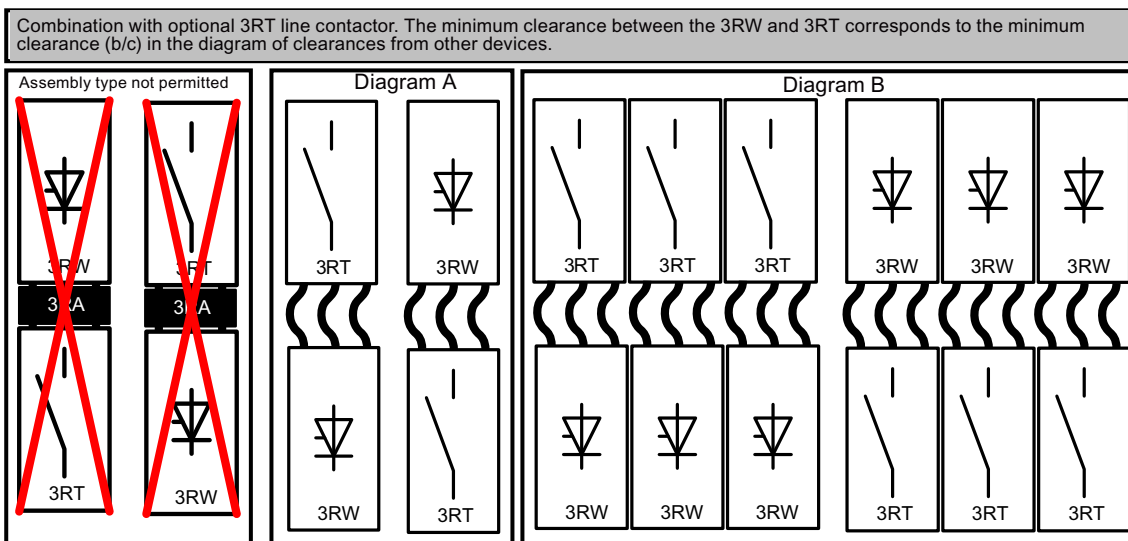
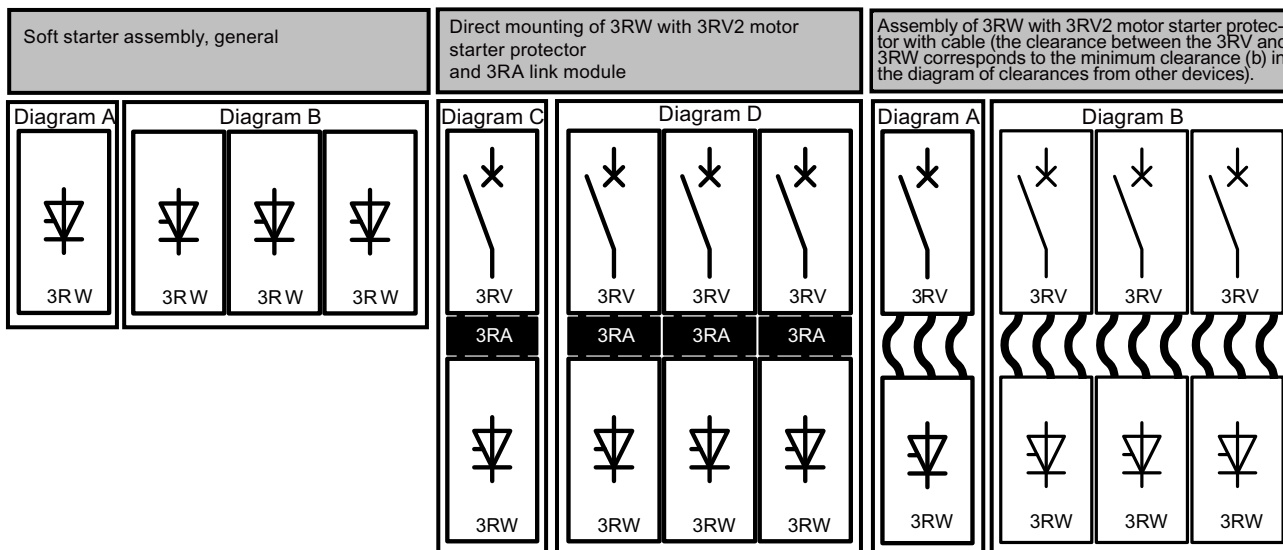

11.7 Calculating the permissible switching frequency

Assembly of 3RW with 3RV2 motor starter protector, 3RA link module, cable, and 3RT line contactor. The minimum clearance between the 3RW, 3RV, and 3RT corresponds to the minimum clearance (b/c) in the diagram of clearances from other devices.

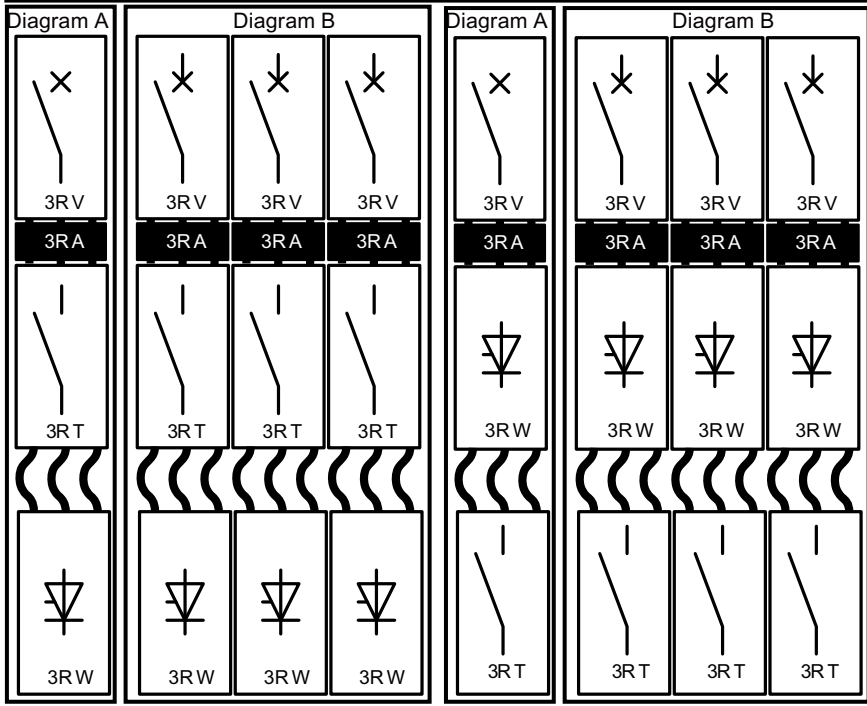

Assembly of 3RW with 3RV2 motor starter protector and 3RT line contactor with cable. The minimum clearance between the 3RV and 3RT corresponds to the minimum clearance (b/c) in the diagram of clearances from other devices.

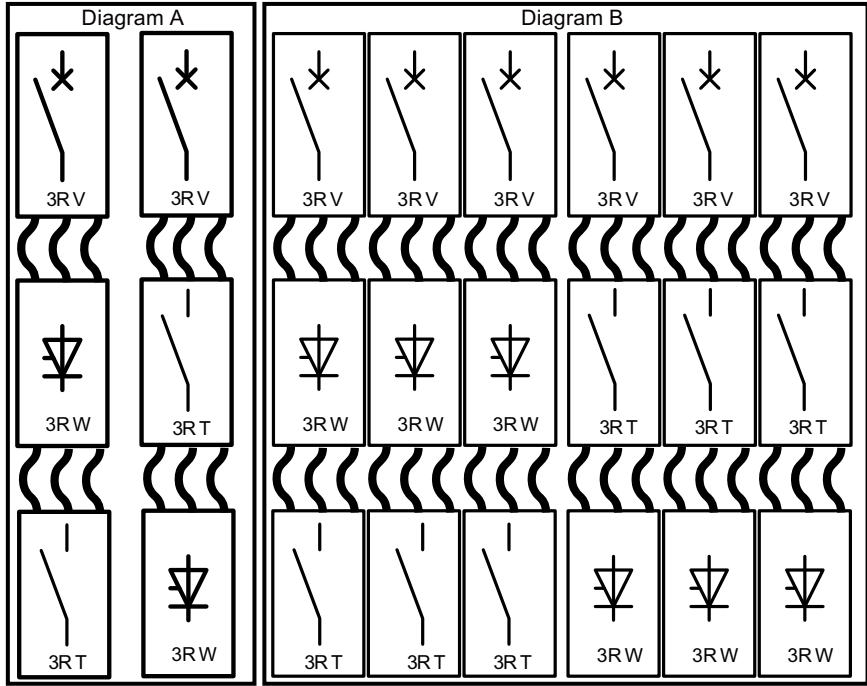

11.7 Calculating the permissible switching frequency

	Article No.	a (mm)	a (in)	b (mm)	b (in)	c (mm)	c (in)
<p>Clearances from other devices</p>	3RW301./3RW302.	15	0.59	60	2.36	40	1.56
	3RW303./3RW304	30	1.18	60	2.36	40	1.56
	3RW402.	15	0.59	60	2.36	40	1.56
	3RW403./3RW404.	30	1.18	60	2.36	40	1.56

11.7.2 Calculating the switching frequency (example)

Problem

The maximum permissible switching frequency of a 5.5 kW (12.5 A) 3RW4024 soft starter must be determined. The requirements are side-by-side assembly and vertical mounting. A run-up time of approx. 3 s at an ambient temperature of 40 °C is specified as a supplementary condition (e.g. a pump motor with CLASS 10 starting). The soft starter must be connected to a 3RV2021 motor starter protector by means of cables. (Clearance between 3RV and 3RW ≥ 40 mm)

Calculating the number of starts / hour of a 3RW40 for side-by-side assembly and vertical mounting

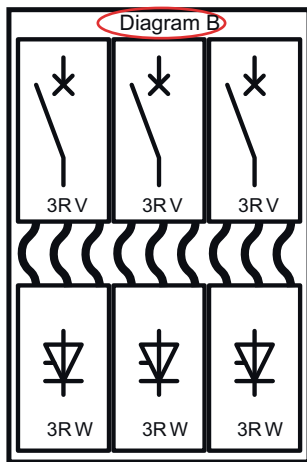

Graph	Assembly type	3RW30			3RW40			3RW40 + optional fan		
		3RW301*	3RW302*	3RW303*	3RW304*	3RW402*	3RW403*	3RW404*	3RW402*	3RW403*
A	Standalone assembly	1.0			1.0			1.6	2.0	2.8
B	Side-by-side assembly	0.7	0.1	0.3	0.1	0.3	1.6	2.0	2.8	
C	Standalone assembly	0.5			0.5			1.6		
D	Side-by-side assembly	0.3	-		-			1.6		

Type		3RW4024
Power electronics		
Load rating with rated operational current I_e		
• According to IEC and UL/CSA ¹⁾ , for standalone assembly, AC-53a		
- At 40°C	A	12.5
- At 50°C	A	11
- At 60°C	A	10
Minimum settable rated motor current I_M for the motor overload protection	A	5
Power loss		
• During operation after successful startup with uninterrupted rated operational current (40°C) approx.	W	2
• During starting with current limit set to 300% I_M (40°C)	W	68
Permissible rated motor current and starts per hour		
• For normal starting (CLASS 10)		
- Rated motor current I_M ²⁾ , ramp-up time 3 s	A	12.5
- Starts per hour ³⁾	1 / h	50

Assembly of a 3RV2021 motor starter protector and connection of a 3RW4024 soft starter with cables and vertical mounting for CLASS 10 starting:

- Switching frequency of 3RW40 with standalone assembly: 50 1/h
- Switching frequency factor for diagram B without a fan: 0.1
- Switching frequency factor for diagram B with a fan ¹⁾: 1.6
- Maximum permissible switching frequency:
- Without fan 50 1/h x 0.1 = 5 1/h
- With fan ¹⁾: 50 1/h x 1.6 = 80 1/h

1) Optional fan: 3RW4928-8VB00

Result

The pump could be started five times an hour providing the above assembly conditions are complied with (side-by-side assembly, vertical mounting). A switching frequency of up to 80 starts per hour can be achieved by equipping the 3RW4026 with the optional 3RW4928-8VB00 fan.

11.8 Configuration aids

11.8.1 Selection of the soft starter using the Simulation Tool for Soft Starters

The screenshot displays the Siemens STS software interface for configuring a soft starter. The main window shows the configuration for a 3RW5226 soft starter. The interface includes a sidebar with a list of suggested soft starters, a main configuration area, and two performance graphs.

Configuration Parameters:

- Model: 3RW5226
- Estimated starting time (application): 4,9 s
- Max. No. Starts / h: 25 x
- Rated current: 77 A
- Thermal load: 4 %
- CLASS: Class 10A

Performance Graphs:

- Torque / Speed:** Shows Soft start motor torque (yellow), D.O.L. motor torque (blue), and Load torque (purple). Key values include 3,2, 2,93, and 238 Nm.
- Current / Speed:** Shows Soft start current (yellow) and D.O.L. current (blue). Key values include 8,4 and 67 A.

Control and Terminal Settings:

- Control supply voltage [V]: AC 110 - 250
- Rated operational voltage: 200V-480V
- Type of terminals: Screw terminals
- Final Article No.: 3RW5226-1AC14

Buttons at the bottom right include 'Save as', 'Order', and 'Report'.

The soft starter can be configured with the STS (Simulation Tool for Soft Starters) software. The STS suggests suitable soft starters for the respective application based on the entered motor and load data and application requirements, as well as providing information on the parameterization.

You can download the Simulation Tool for Soft Starters (STS) for free on the 3RW5 topic page (<https://support.industry.siemens.com/cs/ww/en/view/101494917>).

11.9 Article number system for the 3RW30

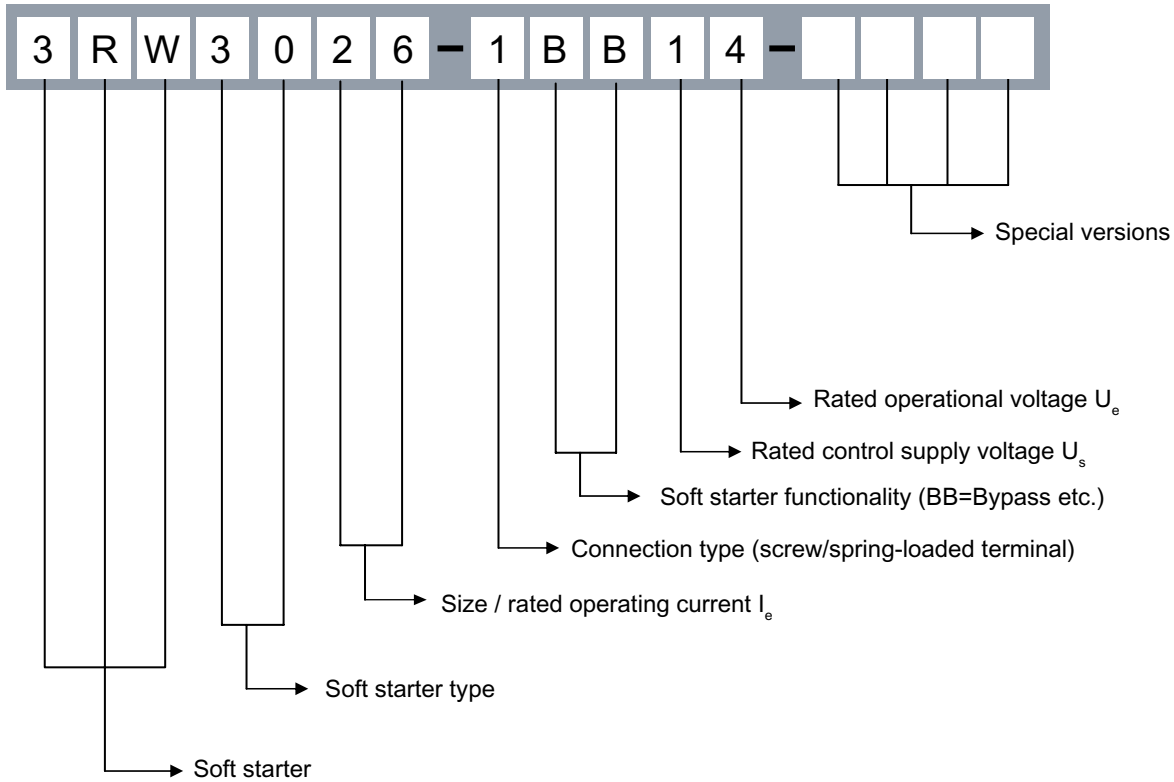

Rated current and rated power at $U_e = 400\text{ V} / 460\text{ V}$ and $T_{amb} = 40\text{ °C} / 50\text{ °C}$

13	$I_e = 3.6\text{ A} / 3\text{ A}$	$P_e = 1.5\text{ kW} / 1.5\text{ hp}$	Size S00
14	$I_e = 6.5\text{ A} / 4.8\text{ A}$	$P_e = 3\text{ kW} / 3\text{ hp}$	
16	$I_e = 9.0\text{ A} / 7.8\text{ A}$	$P_e = 4\text{ kW} / 5\text{ hp}$	
17	$I_e = 12.5\text{ A} / 11\text{ A}$	$P_e = 5.5\text{ kW} / 7.5\text{ hp}$	
18	$I_e = 17.6\text{ A} / 17\text{ A}$	$P_e = 7.5\text{ kW} / 10\text{ hp}$	
26	$I_e = 25\text{ A} / 23\text{ A}$	$P_e = 11\text{ kW} / 15\text{ hp}$	Size S0
27	$I_e = 32\text{ A} / 29\text{ A}$	$P_e = 15\text{ kW} / 20\text{ hp}$	
28	$I_e = 38\text{ A} / 34\text{ A}$	$P_e = 18.5\text{ kW} / 25\text{ hp}$	
36	$I_e = 45\text{ A} / 42\text{ A}$	$P_e = 22\text{ kW} / 30\text{ hp}$	Size S2
37	$I_e = 63\text{ A} / 58\text{ A}$	$P_e = 30\text{ kW} / 40\text{ hp}$	
38	$I_e = 72\text{ A} / 62\text{ A}$	$P_e = 37\text{ kW} / 40\text{ hp}$	
46	$I_e = 80\text{ A} / 73\text{ A}$	$P_e = 45\text{ kW} / 50\text{ hp}$	Size S3
47	$I_e = 106\text{ A} / 398\text{ A}$	$P_e = 55\text{ kW} / 75\text{ hp}$	

For more information, refer to chapter Technical data (Page 125).

11.10 Article number system for the 3RW40

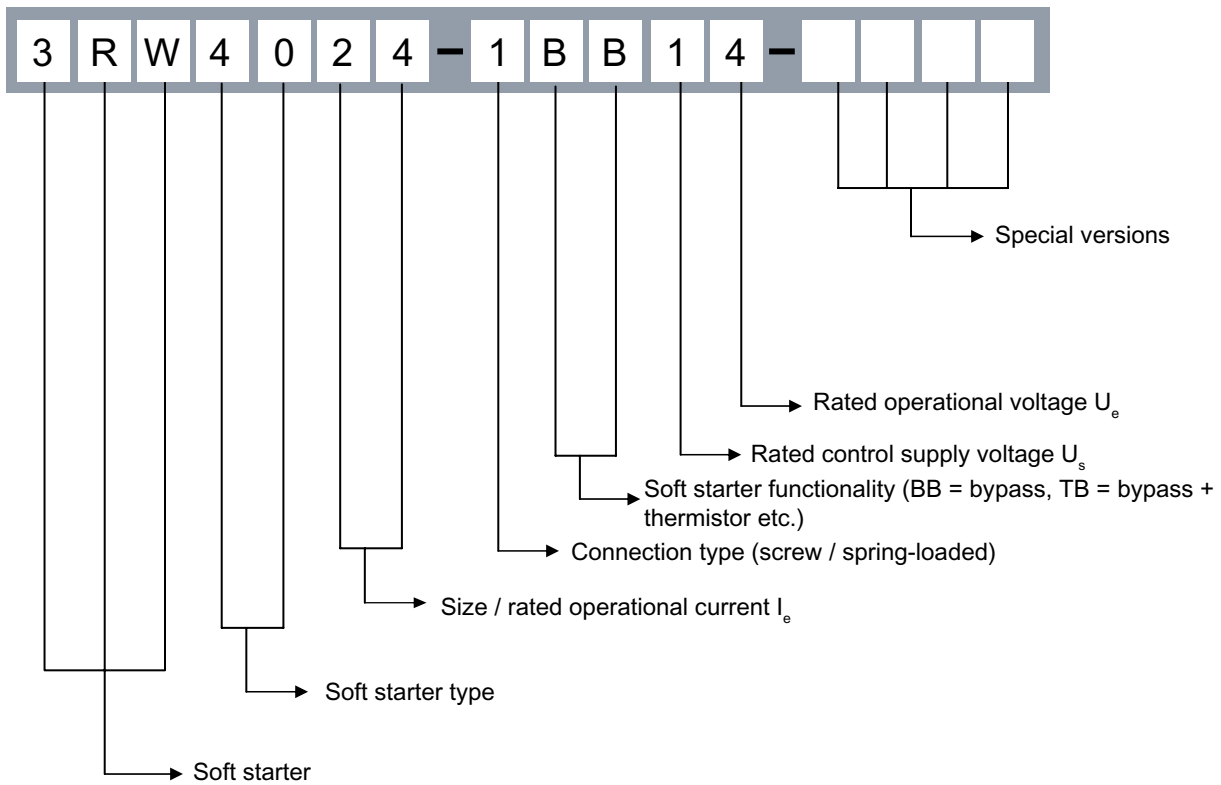

Rated current and rated power at $U_e = 400\text{ V} / 460\text{ V}$ and $T_{amb} = 40\text{ °C} / 50\text{ °C}$

24	$I_e = 12.5\text{ A} / 11\text{ A}$	$P_e = 5.5\text{ kW} / 7.5\text{ hp}$	Size S0
26	$I_e = 25\text{ A} / 23\text{ A}$	$P_e = 11\text{ kW} / 15\text{ hp}$	
27	$I_e = 32\text{ A} / 29\text{ A}$	$P_e = 15\text{ kW} / 20\text{ hp}$	
28	$I_e = 38\text{ A} / 34\text{ A}$	$P_e = 18.5\text{ kW} / 25\text{ hp}$	
36	$I_e = 45\text{ A} / 42\text{ A}$	$P_e = 22\text{ kW} / 30\text{ hp}$	Size S2
37	$I_e = 63\text{ A} / 58\text{ A}$	$P_e = 30\text{ kW} / 40\text{ hp}$	
38	$I_e = 72\text{ A} / 62\text{ A}$	$P_e = 37\text{ kW} / 40\text{ hp}$	
46	$I_e = 80\text{ A} / 73\text{ A}$	$P_e = 45\text{ kW} / 50\text{ hp}$	Size S3
47	$I_e = 106\text{ A} / 98\text{ A}$	$P_e = 55\text{ kW} / 75\text{ hp}$	

For more information, see chapter Technical data (Page 125).

Commissioning

12.1 Commissioning the 3RW30

Commissioning, description of the start and output parameters



12.1.1 Commissioning procedure

1. Check the voltages and wiring.
2. Set the start parameters (for recommended parameters, refer to the quick commissioning table).
3. Start up the motor and if necessary optimize the parameters (refer to the quick commissioning table).
4. Document the parameter settings if required (refer to chapter Table of parameters used (Page 175)).

12.1.2 Quick commissioning of the 3RW30 and optimization of the parameters

CAUTION
 Risk of property damage.
 Connection to unassigned terminals is not permitted.

Recommended setting	Start parameters	
Application	Starting voltage %	Ramp time s
Conveyor belt	70	10
Roller conveyor	60	10
Compressor	50	20
Small fan	40	20
Pump	40	10
Hydraulic pump	40	10
Agitator	40	20

CAUTION
 Risk of property damage.
 Take account of the switching frequency (refer to the technical data).
 The soft starter could be damaged if the switching frequency is too high.

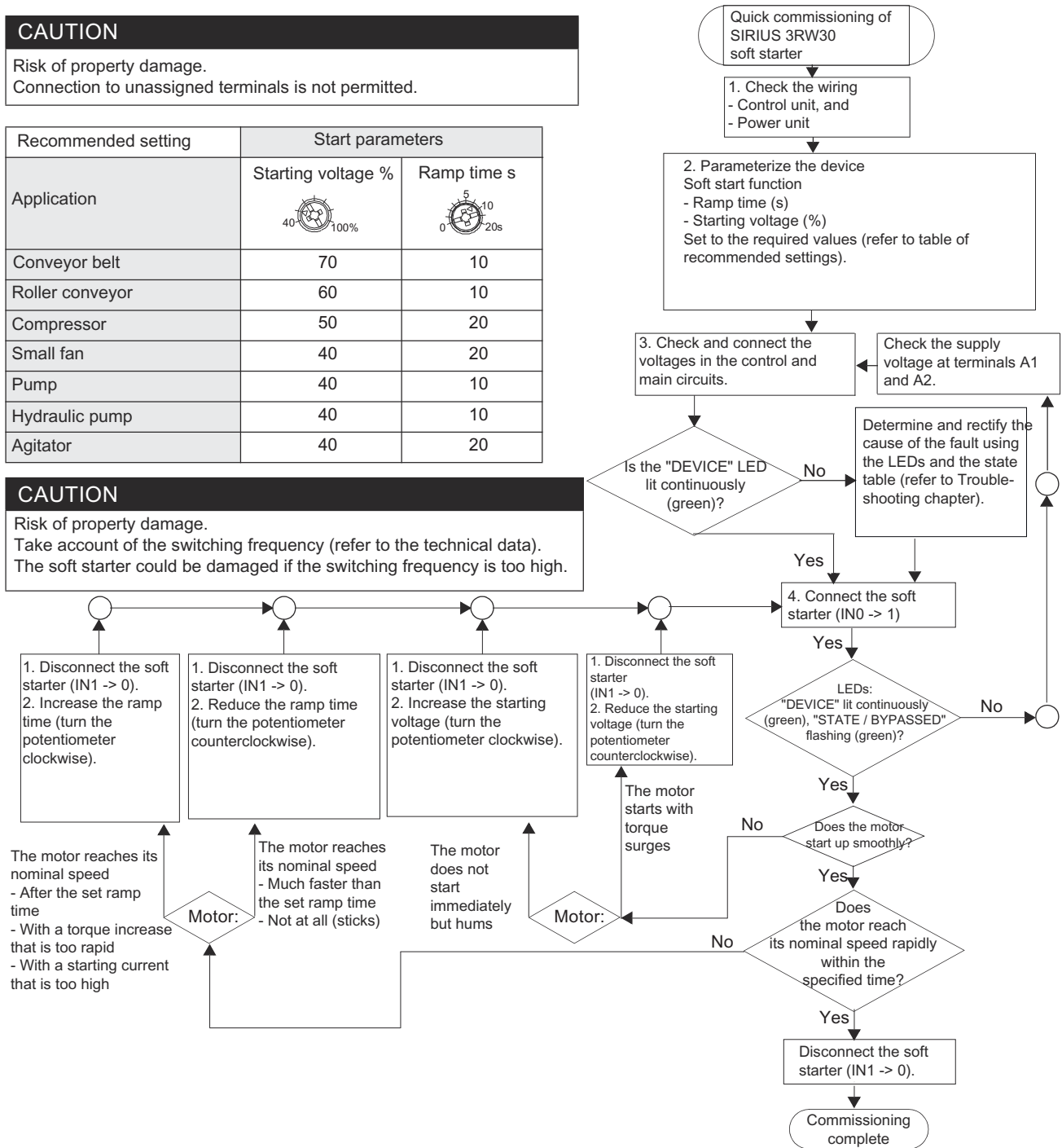

12.1.3 Setting the soft start function

Voltage ramp

The SIRIUS 3RW30 achieves soft starting by means of a voltage ramp. The motor terminal voltage is increased from a parameterizable starting voltage to the mains voltage within a definable ramp time.

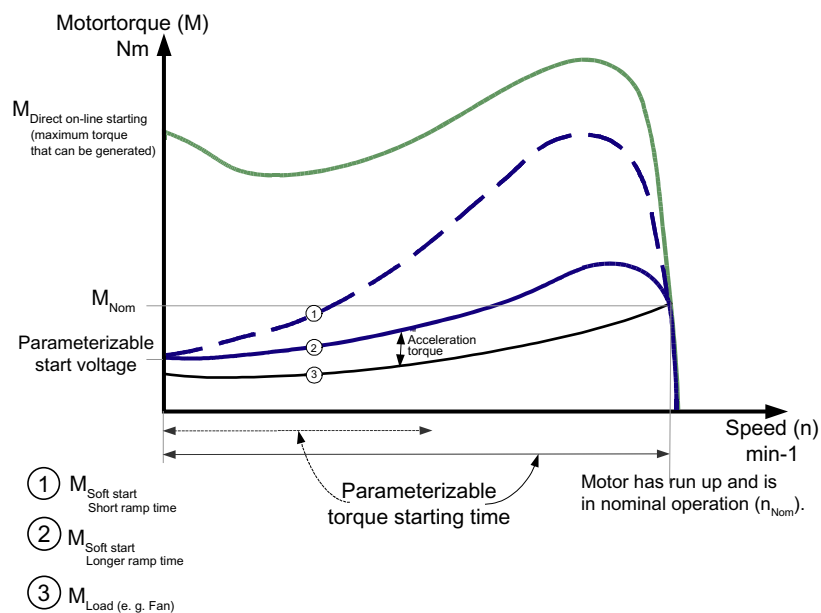
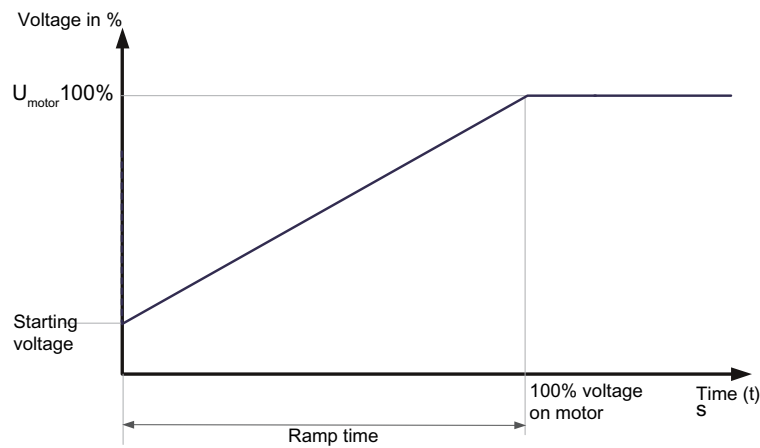

12.1.4 Setting the starting voltage

U potentiometer



The starting voltage value is set with the U potentiometer. This value determines the starting torque of the motor. A lower starting voltage results in a lower starting torque (softer start) and a lower starting current.

The starting voltage selected must be sufficiently high to ensure that motor starts up smoothly as soon as the start command is received by the soft starter.

12.1.5 Setting the ramp time

t potentiometer



You define the length of the required ramp time with the t potentiometer. The ramp time determines the time taken to increase the motor voltage from the parameterized starting voltage to the mains voltage. This time merely influences the motor's acceleration torque, which drives the load during the ramp-up process. The actual motor starting times are load-dependent and can differ from the 3RW soft starter settings.

A longer ramp time results in a lower starting current and a reduced acceleration torque as the motor starts up. The startup is slower and smoother as a result. The ramp time must be long enough for the motor to reach its nominal speed. If the time selected is too short, in other words if the ramp time ends before the motor has started up successfully, a very high starting current that can even equal the direct starting current at the same speed occurs at this instant.

The SIRIUS 3RW30 soft starter can be damaged in this application (set ramp time shorter than the actual motor ramp-up time). A maximum ramp-up time of 20 s is possible for the

3RW30. An appropriately dimensioned SIRIUS 3RW40 or 3RW55 soft starter should be chosen for startup processes with a motor ramp-up time > 20 s.

NOTICE

Risk of property damage

Make sure the selected ramp time is longer than the actual motor ramp-up time. If not, the SIRIUS 3RW30 may be damaged because the internal bypass contacts close when the set ramp time elapses. If the motor has not finished starting up, an AC3 current that could damage the bypass contact system will flow.

When using the 3RW40: The 3RW40 has an integrated ramp-up detection function that prevents this operating state from occurring.

12.1.6 ON output

ON output contact

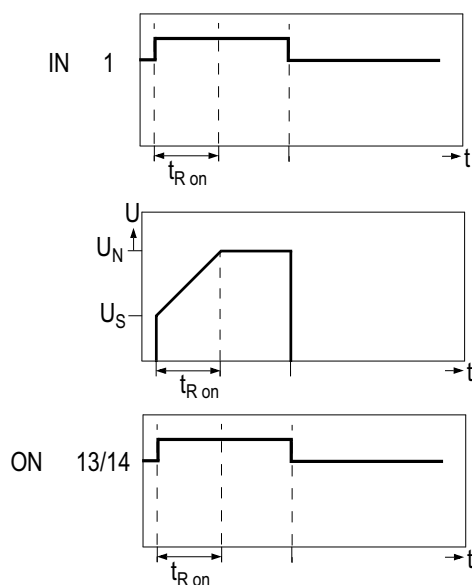

State diagram of the ON output contact

The output contact at terminal 13/14 (ON) closes if a signal is present at terminal 1 (IN); it remains closed until the start command is removed.

The output can be used, for instance, to control a line contactor connected upstream or to implement latching if you selected pushbutton control. For recommended circuits, refer to chapter Typical circuit diagrams (Page 147).

For the state diagram of the contacts in the various operating states, refer to chapter 3RW30: LEDs (Page 57).

12.2 Commissioning the 3RW40

Commissioning, description of the start, stop, motor protection, and output parameters



12.2.1 Commissioning procedure

1. Check the voltages and wiring.
2. Set the start and stop parameters (for recommended parameters, refer to the quick commissioning table).
3. Set the motor overload function (if required)
4. Define the RESET mode if a failure occurs.
5. Start up the motor and if necessary optimize the parameters (refer to the quick commissioning table).
6. Document the parameter settings if required.

12.2.2 Quick commissioning of the 3RW40 and optimization of the parameters

CAUTION
 Risk of property damage.
 Connection to unassigned terminals is not permitted.

Quick commissioning of SIRIUS 3RW40 soft starter

1. Check the wiring
 - Control unit, and
 - Power unit

Recommended setting	Start parameters			Stop parameter
	Starting voltage %	Ramp time s	Current limiting value	Ramp-down time s
Application				
Conveyor belt	70	10	5 x I _e	5
Roller conveyor	60	10	5 x I _e	5
Compressor	50	10	4 x I _e	0
Small fan	40	10	4 x I _e	0
Pump	40	10	4 x I _e	10
Hydraulic pump	40	10	4 x I _e	0
Agitator	40	20	4 x I _e	0
Milling machine	40	20	4 x I _e	0

2. Parameterize the device
 Motor protection
 - Set the rated motor current of the operating mechanism with the I_e adjuster
 - Set the required trip class with the CLASS switch
 Soft start function
 - Current limiting value (x I_e)
 - Ramp time (s)
 - Ramp-down time (s)
 Set to the required values (refer to table of recommended settings).

3. Check and connect the voltages in the control and main circuits.
 Determine and rectify the cause of the fault using the LEDs and the state table. (refer to Troubleshooting chapter)

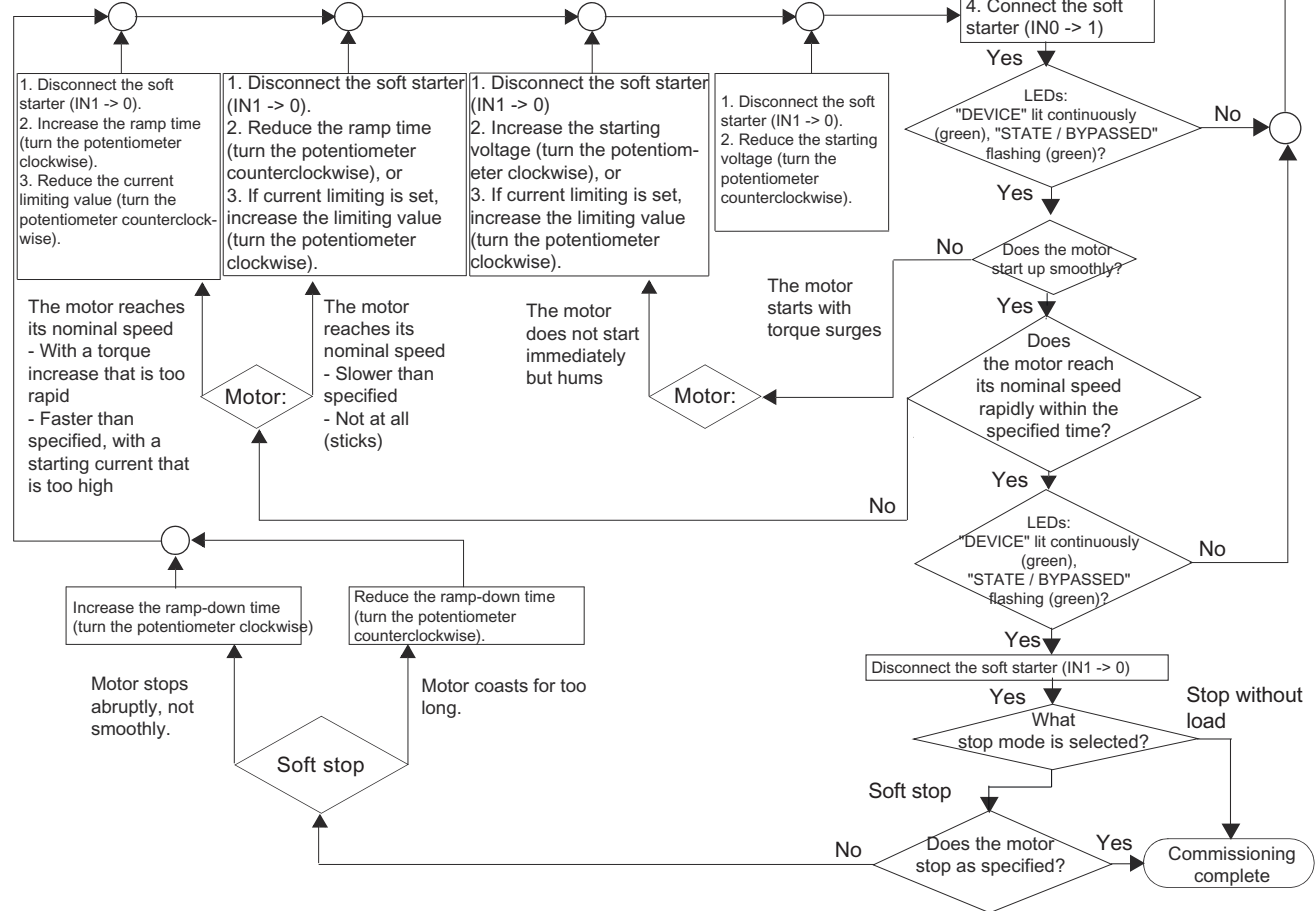

12.2.3 Setting the soft start function

Voltage ramp

The SIRIUS 3RW40 achieves soft starting by means of a voltage ramp. The motor terminal voltage is increased from a parameterizable starting voltage to the mains voltage within a definable ramp time.

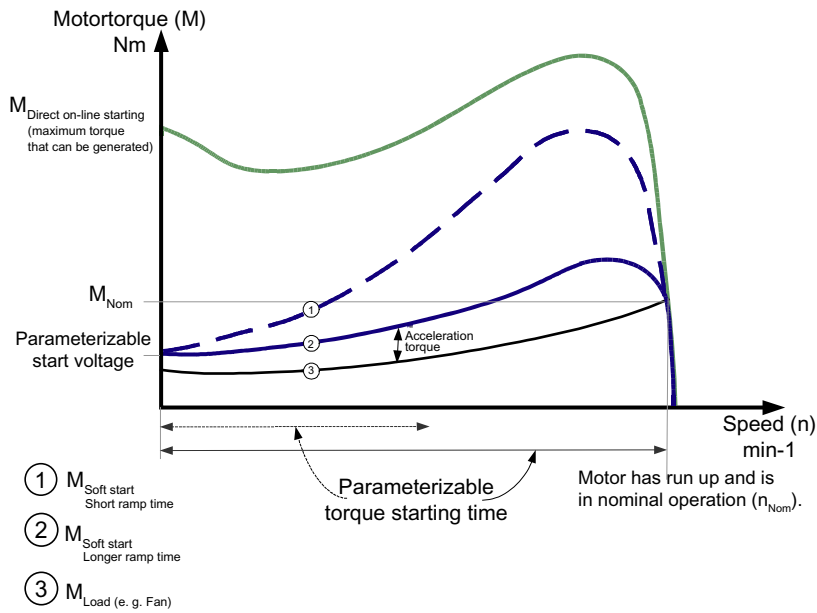
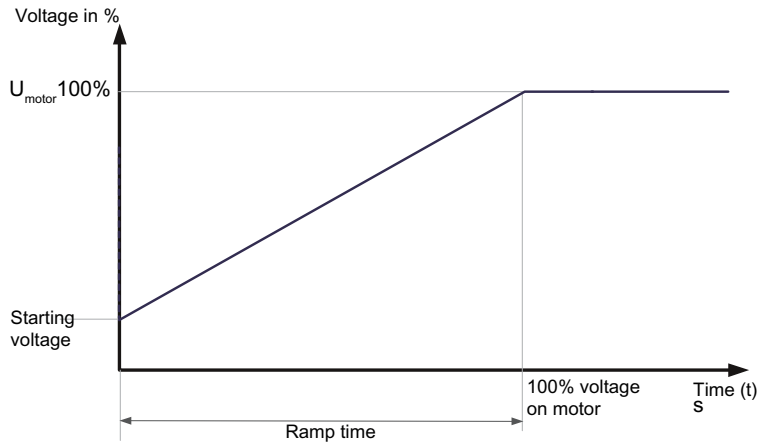

12.2.4 Setting the starting voltage

U potentiometer



The starting voltage value is set with the U potentiometer. This value determines the starting torque of the motor. A lower starting voltage results in a lower starting torque (softer start) and a lower starting current.

The starting voltage selected must be sufficiently high to ensure that motor starts up smoothly as soon as the start command is received by the soft starter.

12.2.5 Setting the ramp time

t potentiometer



You define the length of the required ramp time with the t potentiometer. The ramp time determines the time taken to increase the motor voltage from the parameterized starting voltage to the mains voltage. This time merely influences the motor's acceleration torque, which drives the load during the ramp-up process. The actual motor starting times are load-dependent and can differ from the 3RW soft starter settings.

A longer ramp time results in a lower starting current and a reduced acceleration torque as the motor starts up. The startup is slower and smoother as a result. The ramp time must be long enough for the motor to reach its nominal speed. If the time selected is too short, in other words if the ramp time ends before the motor has started up successfully, a very high starting current that can even equal the direct starting current at the same speed occurs at this instant.

The SIRIUS 3RW40 soft starter additionally limits the current to the value set with the current limiting potentiometer. As soon as the current limiting value is reached, the voltage ramp or the ramp time is interrupted and the motor is started with the current limiting value until it has started up successfully. In this case, the motor ramp-up times may be longer than the maximum parameterizable 20 seconds ramp time or the ramp time that is actually set on the soft starter (for further information about the maximum ramp-up times and switching frequencies, refer to the Technical data chapter > 3RW30 13, 14, 16, 17, 18-BB.. power electronics (Page 128)) ff. and 3RW40 24, 26, 27, 28 power electronics (Page 138) ff.).

12.2.6 Current limiting in conjunction with a starting voltage ramp and ramp-up detection

Current limiting

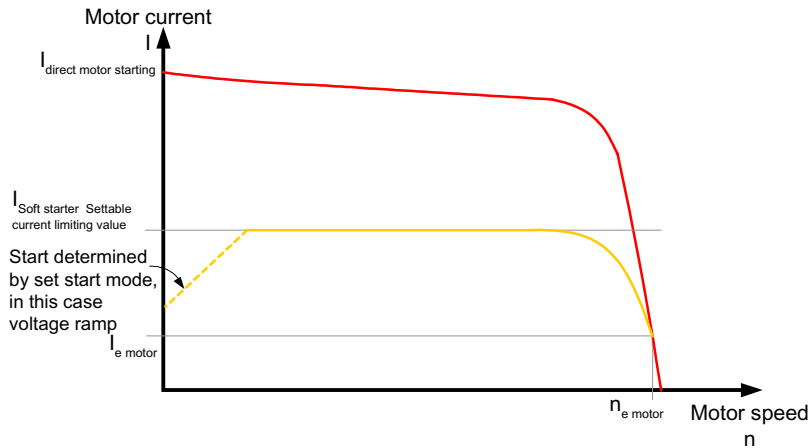

The SIRIUS 3RW40 soft starter measures the phase current (motor current) continuously with the help of integrated current transformers.

The motor current that flows during the startup process can be actively limited by means of the soft starter. The current limiting function takes priority over the voltage ramp function.

As soon as a parameterizable current limit is reached, in other words, the voltage ramp is interrupted and the motor is started with the current limiting value until it has started up successfully. The current limiting function is always active with SIRIUS 3RW40 soft starters.

If the current limiting potentiometer is set to clockwise stop, the starting current is limited to the maximum possible current (refer to chapter Setting the current limiting value (Page 113)).

12.2.7 Setting the motor current

I_e potentiometer

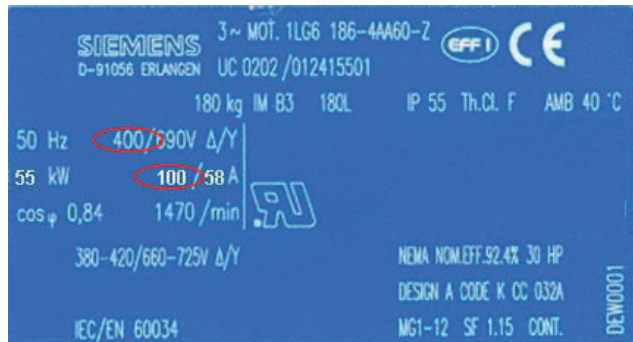

The rated operational current of the motor must be set with the I_e potentiometer according to the mains voltage and the motor connection (wye-delta). The electronic motor overload protection also refers to this set value if it is active. For the permissible settings referred to the required motor overload trip class, refer to chapter Motor current settings (Page 118).

12.2.8 Setting the current limiting value

xI_e potentiometer



Representation valid for 3RW40 S0, S2, S3 up to product version E06



Representation valid for 3RW40 S0, S2, S3 as of product version E07

The current limiting value is set with the xI_e potentiometer to the maximum required starting current as a factor of the set rated motor current (I_e).

Example

- I_e potentiometer set to 100 A
- xI_e potentiometer set to 5 \Rightarrow current limiting 500 A.

As soon as the selected current limiting value is reached, the motor voltage is reduced or controlled by the soft starter to prevent the current from exceeding the limit. Since the starting current is asymmetrical, the set current corresponds to the arithmetic mean value for the three phases.

If the current limiting value is set to the equivalent of 100 A, the starting currents might be approx. 80 A in L1, 120 A in L2, and 100 A in L3 (refer to chapter Starting current asymmetry (Page 31)).

The set current limiting value must be high enough to ensure that the torque generated in the motor is sufficient to accelerate the motor to nominal speed. Three to four times the value of the motor's rated operational current (I_e) can be assumed as typical here.

The current limiting function is always active because it is required by the intrinsic device protection. If the current limiting potentiometer is set to clockwise stop, the starting current is limited to the maximum possible current. We must differentiate between two cases here:

Scenario A:

3RW40 devices up to product version E06 (for 3RW40 size S0, S2, S3)

\Rightarrow The maximum possible limiting current is 5 times the value of the rated motor current set on the 3RW40 soft starter (refer to chapter Setting the motor current (Page 112)).

Scenario B:

3RW40 devices from product version E07 (for 3RW40 size S0, S2, S3)

⇒ On these 3RW40 devices, the maximum possible limiting current ("max" setting) is 5 times the value of the maximum rated operational current set on the soft starter (see the rating plate of the soft starter). This value depends on the rated motor current actually set on the 3RW40 soft starter (potentiometer I_e). This value is identical with 5 times the maximum value that can be set on the potentiometer I_e .

Overdimensioning, due to motors with high starting current conditions, for example

For dimensioning soft starters for motors with high starting current conditions (typically $I/I_e \geq 8$) observe the configuring information in the chapter Dimensioning of soft starters for motors with high starting current conditions (Page 91).

12.2.9 Optimized setting ranges for current limiting

Example of optimized current limiting setting ranges for the 3RW40 soft starters

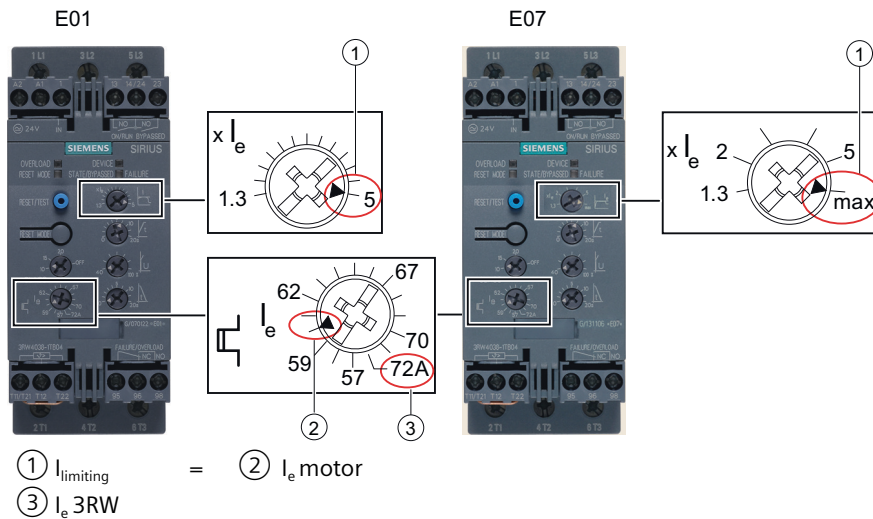
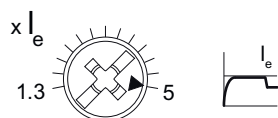

Figure 12-1 Optimized current limiting setting ranges

Example of calculating the current limiting

Up to product version E06 (for 3RW40 size S0, S2, S3)



$$\begin{aligned} I_{e \text{ motor}} &= 60 \text{ A} \\ I_{e \text{ 3RW}} &= 72 \text{ A} \\ I_{\text{limiting}} &= 1 \dots 5 \times I_{e \text{ motor}} \\ I_{\text{max}} &= 5 \times I_{e \text{ motor}} = 300 \text{ A} \end{aligned}$$

As of product version E07 (for 3RW40 size S0, S2, S3)

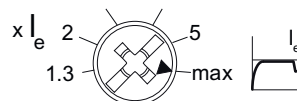

$$\begin{aligned} I_{e \text{ motor}} &= 60 \text{ A} \\ I_{e \text{ 3RW}} &= 72 \text{ A} \\ I_{\text{limiting}} &= 1 \dots 5 \times I_{e \text{ motor}} \\ I_{\text{max}} &= 5 \times I_{e \text{ 3RW}} = \mathbf{360 \text{ A}} \end{aligned}$$

For setting values, see Optimized setting ranges for current limiting (Page 114).

12.2.10 Ramp-up detection

The SIRIUS soft starter has a motor ramp-up detection function that is always active regardless of the start mode. If it detects a motor startup, the motor voltage is immediately increased to 100 % of the mains voltage. The thyristors of the soft starter are bridged by the bypass contacts integrated in the device and the successful startup is indicated by means of the BYPASS output and the STATE / BYPASSED LED.

12.3 Setting the soft stop function

In "soft stop" mode, the natural stop process of the load is decelerated. The function is used when the load must be prevented from stopping abruptly. This is typically the case in applications with a low mass inertia or a high counter-torque.

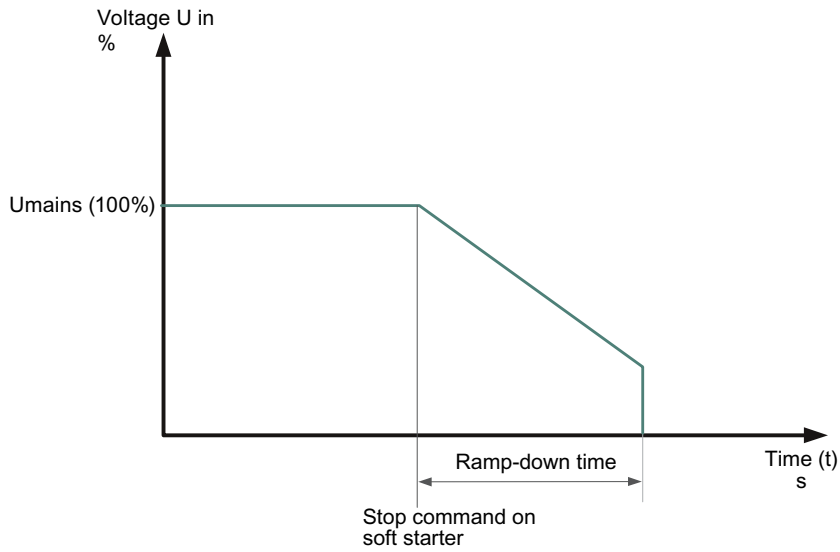

12.3.1 Setting the ramp-down time

t potentiometer



You can set a ramp-down time with the t potentiometer. This determines how long power should still be supplied to the motor after the ON command is removed. The torque generated in the motor is reduced by means of a voltage ramp function within this ramp-down time and the application stops smoothly.

If the potentiometer is set to 0, there is no voltage ramp during stopping (stop without load).

12.4 Setting the motor protection function

The motor overload protection function is implemented on the basis of the winding temperature. This indicates whether the motor is overloaded or functioning in the normal operating range.

The winding temperature can either be calculated with the help of the integrated, electronic motor overload function or measured with a connected motor thermistor.

12.4.1 Setting the electronic motor overload protection

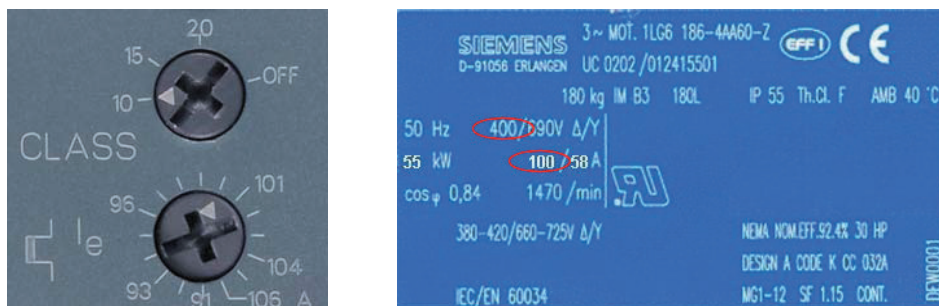

I_e potentiometer

The rated operational current of the motor must be set with the I_e potentiometer according to the mains voltage and the motor connection (wye-delta).

The current flow during motor operation is measured by measuring the current with transformers integrated in the soft starter. This value is also used for the current limiting function. The temperature rise in the winding is calculated based on the rated operational current set for the motor.

CLASS potentiometer

You can set the required trip class (10, 15, or 20) with the CLASS potentiometer. A trip is generated by the soft starter when the standardized characteristic is reached, depending on the trip class (CLASS setting).

The trip class specifies the maximum time within which a protective device must trip from a cold state at $7.2 \times$ the rated operational current (motor protection to IEC 60947). The tripping characteristics represent this time as a function of the tripping current (refer to chapter Motor protection tripping characteristics for 3RW40 (with symmetry) (Page 143)).

12.4 Setting the motor protection function

You can set different CLASS characteristics according to the startup class. If the potentiometer is set to OFF, the "electronic motor overload protection" function is deactivated.

Note

The rated data of the soft starters refers to normal starting (CLASS 10). The starters may need to be calculated with a size allowance for heavy-duty starting (> CLASS 10). You can only set a rated motor current that is lower than the soft starter rated current (refer to chapter Motor current settings (Page 118)); if not, a fault will be indicated by the OVERLOAD LED (red flashing) and it will not be possible to start the SIRIUS 3RW soft starter.

12.4.2 Motor current settings

	I_e [A]	I_{min} [A]	I_{max} [A] CLASS 10	I_{max} [A] CLASS 15	I_{max} [A] CLASS 20
3RW4024-...	12.5	5	12.5	11	10
3RW4026-...	25.3	10.3	25.3	23	21
3RW4027-...	32.2	17.2	32.2	30	27
3RW4028-...	38	23	38	34	31
3RW4036-...	45	22.5	45	42	38
3RW4037-...	63	25.5	63	50	46
3RW4038-...	72	34.5	72	56	50
3RW4046-...	80	42.5	80	70	64
3RW4047-...	106	46	106	84	77

12.4.3 Motor protection acc. to ATEX

Refer to the information in chapter Motor protection / intrinsic device protection (3RW40 only) (Page 44).

12.5 Thermistor motor protection

(Optional for 3RW402. to 3RW404. with 24 V AC/DC rated control voltage)

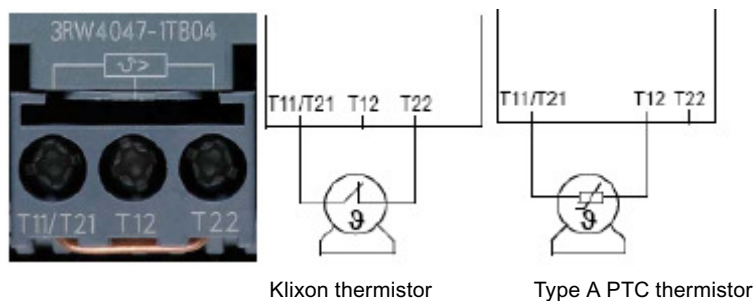

Thermistor motor protection

After removing the copper jumper between T11/21 and T22, you can connect and evaluate either a Klaxon thermistor integrated in the motor winding (at terminal T11/T21-T22) or a type A PTC (at terminal T11/T21-T12).

12.6 Motor protection trip test

RESET / TEST button



You initiate a motor overload trip by pressing the RESET / TEST button for longer than five seconds. The SIRIUS 3RW40 soft starter is tripped by the fault signal at the OVERLOAD LED, the FAILURE / OVERLOAD contact 95-98 closes, and the motor that is connected and running is switched off.

12.7 Functions of the outputs

12.7.1 Functions of the BYPASSED and ON / RUN outputs

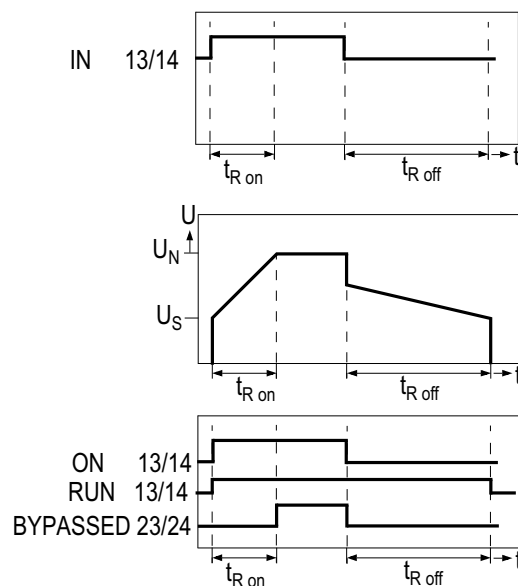

BYPASSED output contact

The BYPASSED output at terminal 23 / 24 closes as soon as the SIRIUS 3RW40 soft starter detects that the motor has started up (refer to chapter Ramp-up detection (Page 115)). The integral bypass contacts simultaneously close and the thyristors are bridged. The integral bypass contacts and output 23 / 24 open again as soon as the start input IN is removed.

ON / RUN output contact

ON function set: The potential-free output contact at terminal 13/14 (ON) closes if a signal is present at terminal 1 (IN); it remains closed until the start command is removed (factory default). The ON function can be used, for instance, as a latching contact if you selected pushbutton control (refer to chapter Control by pushbutton (Page 148)).

Reparameterizing the output of the ON function (factory default) to RUN

You can reparameterize the output function from ON to RUN by simultaneously pressing two buttons (refer to chapter Parameterizing the 3RW40 outputs (Page 122)).

RUN function set: The potential-free output contact at terminal 13/14 closes if a signal is present at terminal 1 (IN); it remains closed until the start command is removed and after that until the set ramp-down time has elapsed.

12.7 Functions of the outputs

If the RUN function is set, you can control a line contactor during the startup process, operation, or the set soft stop (refer to chapter Control with an optional main / line contactor (Page 157))

For recommended circuits, refer to chapter Typical circuit diagrams (Page 147).

12.7.2 Parameterizing the 3RW40 outputs

Programming the ON / RUN output 13/14 on the SIRIUS 3RW40 soft starter

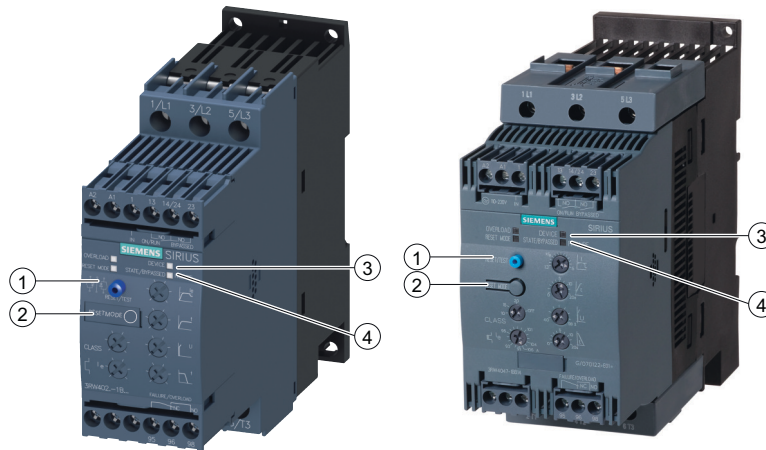

















Figure 12-2 Overview of buttons/LEDs for 3RW40 2 - 3RW404

	A	B	C	D	E
RESET / TEST (1)			 >1 s		 >1 s
RESET MODE (2)			 > 2 s		
		=	=	=	=
DEVICE (3)	GN 	GN 	RD 	RD 	GN 
STATE BYPASSED (4)	● OFF	● OFF	◐ ON/ ◑ RUN	◑ RUN/ ◐ ON	● OFF
FAILURE	● OFF	● OFF	● OFF	● OFF	● OFF
AUTO	● / 	 / ●			● / 

			
OFF / off	ON / on	Flashing	Flickering

Reparameterizing the ON / RUN output

A: Control voltage is present and the soft starter is in the normal, fault-free position:
The DEVICE LED is continuously lit (green) while the STATE / BYPASSED and FAILURE LEDs are off.
The AUTO LED indicates the color of the set RESET mode.

B: Start programming:
(On the 3RW402 device, remove the RESET MODE cover as shown in chapter Setting the RESET MODE (Page 49).) Press the RESET MODE button (2) for longer than 2 s until the DEVICE LED (3) flickers (green). Hold the RESET MODE button (2) pressed down.

C: Simultaneously press the RESET/TEST button (1) for longer than 1 s until the DEVICE LED (3) lights up (red). The active mode set at the ON / RUN output is indicated by the STATE / BYPASSED / FAILURE LED (4):

STATE / BYPASSED / FAILURE LED (4) flashes (green): ON mode (factory setting).

STATE / BYPASSED / FAILURE LED (4) flickers (green): RUN mode.

D: Change the mode:

Press the RESET MODE button (2) briefly. By pressing this button, you change the mode at the output, and the new mode is indicated by the STATE / BYPASSED / FAILURE LED (4):

STATE / BYPASSED / FAILURE LED (4) flickers (green): RUN mode is set.

STATE / BYPASSED / FAILURE LED (4) flashes (green): ON mode is set.

E: Exit programming and save the settings:

Press the RESET / TEST MODE button (1) for longer than 1 s until the DEVICE LED (3) lights up (green).

The LEDs indicate the following states again if the output was successfully parameterized:

DEVICE LED: Continuously lit (green). STATE / BYPASSED and FAILURE LEDs: Off.

The AUTO LED indicates the color of the set RESET mode.

12.7.3 Function of the FAILURE / OVERLOAD output



FAILURE / OVERLOAD output contact

If there is no rated control voltage or if a failure occurs, the potential-free FAILURE / OVERLOAD output is switched.

Note

For information about whether or not faults can be acknowledged, as well as the recovery time and the corresponding LED and output contact states, refer to chapter Messages and diagnosis (Page 57).

Technical data

13.1 Technical specifications in the Siemens SiePortal

Technical data sheet

You can find the technical specifications for the product in Siemens SiePortal (<https://support.industry.siemens.com/cs/ww/en/ps/25247/td>).

1. Enter the article number of the desired device in the "Products" field.
2. Click the "Technical specifications" link in the result.

13.2 3RW30

13.2.1 Overview

SIRIUS 3RW30 soft starters reduce the motor voltage through variable phase angle control and increase it from a selectable starting voltage up to the mains voltage within the ramp time. They limit the starting current and torque, so that the shocks that occur during direct starts or wye-delta starting are avoided. Mechanical loads and mains voltage dips can be effectively prevented in this way.

Soft starting reduces the stress on the connected equipment, resulting in lower wear and therefore longer periods of trouble-free production. The selectable starting voltage means the soft starters can be individually adjusted to the requirements of the application in question and – unlike wye-delta starters – are not restricted to two-stage starting with fixed voltage ratios.

SIRIUS 3RW30 soft starters are characterized above all by their small space requirements. Integral bypass contacts mean that no power loss has to be taken into account at the power semiconductors (thyristors) after the motor has started up. This cuts down on heat losses, enabling a more compact design and making external bypass circuits superfluous.

Soft starters rated up to 55 kW (at 400 V) can be supplied for standard applications in three-phase systems. Extremely small sizes, low power losses and simple startup are just three of the many advantages of this soft starter.

Note

The rated motor current is extremely important when selecting a soft starter.

Refer to the information about selecting soft starters in chapter Configuration (Page 83).

Conditions for normal starting:

Max. ramp time 3 s, starting current 300%, 20 starts/hour, ON time 30%, standalone assembly, max. installation altitude 1000 m / 3280 ft, ambient temperature kW 40 °C / 104 °F. In the event of deviating conditions or increased switching frequency, it may be necessary to choose a larger device. For information about the rated currents for ambient temperatures above 40 °C, refer to chapter 3RW30...BB.. power electronics (Page 128).

13.2.2 3RW30...BB.. control electronics

Type	3RW301., 3RW302.		3RW303., 3RW304.	
Control electronics				
Rated values	Terminal			
Rated control supply voltage	A1 / A2	V	24	110...230
• Tolerance		%	±20	-15/+10
Rated control supply current				
• STANDBY		mA	<50	6
• During pickup		mA	<100	15
• ON		mA	<100	15
Rated frequency		Hz	50/60	
• Tolerance		%	±10	
Control input			ON / OFF	
IN				
Power consumption with version			approx. 12	
• 24 V DC		mA	AC: 3/6; DC: 1.5/3	
• 110/230 V AC		mA		
Relay outputs				
Output 1	ON	13/14	Operating indication (NO)	
Rated operational current		A	3AC-15/AC-14 at 230 V,	
		A	1DC-13 at 24 V	
Protection against overvoltages			Protection by means of varistor through contact	
Short-circuit protection			4 A gL/gG operational class;	
			6 A quick (fuse is not included in scope of supply)	
Operating indications		LED	DEVICE	STATE/BYPASSED/ FAILURE
Off			Green	Green
Start			Green	Green flashing
Bypass			Green	Green
Fault signals				
• 24 V DC: $U < 0.75 \times U_s$ or $U > 1.25 \times U_s$			Off	Red
• AC 110...230 V: $U < 0.75 \times U_s$ or $U > 1.15 \times U_s$			Off	Red
Electrical overloading of bypass (reset by removing IN command)			Yellow	Red
Missing mains voltage, phase failure / missing load			Green	Red
Device fault			Red	Red

13.2.3 3RW30...BB.. control times and parameters

Type	3RW301....3RW304.		Factory default
Control times and parameters			
Control times			
Closing delay (with connected control voltage)	ms	<50	
Closing delay (automatic / line contactor mode)	ms	<300	
Mains failure bridging time			
Control supply voltage	ms	50	
Mains failure response time ¹⁾			
Load current circuit	ms	500	
Start parameters			
• Ramp-up time	s	0...20	7.5
• Starting voltage	%	40...100	40
Ramp-up detection		No	
Operating mode output 13/14			
Rising edge at	Start command	ON	
Falling edge at	Off command		

1) Mains failure detection only in standby state, not during operation.

13.2 3RW30

13.2.4 3RW30...BB.. power electronics

Type	3RW301...BB.4...3RW304...BB.4	
Power electronics		
Rated operational voltage	V AC	200...480
Tolerance	%	-15/+10
Rated frequency	Hz	50/60
Tolerance	%	±10
Continuous duty at 40°C (% of I _e)	%	115
Minimum load (% of I _e)	%	10 (at least 2 A)
Maximum cable length between soft starter and motor	m	300
Permissible installation altitude	m	5000 (Derating from 1000, see characteristic curves); higher on request
Permissible mounting position (auxiliary fan not available)		
Permissible ambient temperature	°C	-25...+60; (derating from +40)
Operation	°C	-40...+80
Storage	°C	-40...+80
Degree of protection	IP20 for 3RW301. and 3RW302.; IP00 for 3RW303. and 3RW304.	

13.2.5 3RW30 13, 14, 16, 17, 18-BB.. power electronics

Type		3RW3013	3RW3014	3RW3016	3RW3017	3RW3018
Power electronics						
Current carrying capacity rated operating current I _e						
• Acc. to IEC and UL/CSA ¹⁾ , for standalone assembly, AC-53a						
- At 40 °C	A	3.6	6.5	9	12.5	17.6
- At 50 °C	A	3.3	6	8	12	17
- At 60 °C	A	3	5.5	7	11	14
Power loss						
• During operation after startup of the motor at uninterrupted rated operat. curr. (40°C) approx.	W	0,25	0,5	1	2	4
• During starting at 300 % I _M (40 °C)	W	24	52	80	80	116
Permissible rated motor current and starts per hour for normal starting (class 10):						
- Rated motor curr. I _M ²⁾ , ramp-up time 3s	A	3.6 / 3.3	6,5 / 6,0	9 / 8	12.5 / 12.0	17.6 / 17.0
- Starts per hour ³⁾	1/h	200 / 150	87 / 60	50 / 50	85 / 70	62 / 46
- Rated motor curr. I _M ²⁾ , ramp-up time 4s	A	3.6 / 3.3	6,5 / 6,0	9 / 8	12.5 / 12.0	17.6 / 17.0
- Starts per hour ³⁾	1/h	150 / 100	64 / 46	35 / 35	62 / 47	45 / 32

1) Measurement at 60 °C in accordance with UL/CSA not required.

2) At 300 % I_M. Tamb = 40 °C / 50 °C

3) For intermittent duty S4 with ON time 30 %, T_{amb} = 40 °C / 50 °C, vertical standalone assembly. The specified switching frequencies do not apply to automatic mode.

13.2.6 3RW30 26, 27, 28-.BB.. power electronics

Type		3RW3026	3RW3027	3RW3028
Power electronics				
Current carrying capacity rated operating current I_e				
• Acc. to IEC and UL/CSA ¹⁾ , for standalone assembly, AC-53a				
- At 40 °C	A	25.3	32.2	38
- At 50 °C	A	23	29	34
- At 60 °C	A	21	26	31
Power loss				
• During operation after startup of the motor at uninterrupted rated operat. curr.(40 °C) approx.	W	8	13	19
• During starting at 300 % $I_M(40 °C)$	W	188	220	256
Permissible rated motor current and starts per hour at normal starting (class 10)				
- Rated motor curr. $I_M^{(2)}$, ramp-up time 3s	A	25 / 23	32 / 29	38 / 34
- Starts per hour ³⁾	1/h	23 / 23	23 / 23	19 / 19
- Rated motor curr. $I_M^{(2)}$, ramp-up time 4s	A	25 / 23	32 / 29	38 / 34
- Starts per hour ³⁾	1/h	15 / 15	16 / 16	12 / 12

1) Measurement at 60 °C in accordance with UL/CSA not required.

2) At 300 % I_M . $T_{amb} = 40 °C / 50 °C$

3) For intermittent duty S4 with ON time 30 %, $T_{amb} = 40 °C / 50 °C$, vertical standalone assembly. The specified switching frequencies do not apply to automatic mode. Factors for permissible switching frequency with different mounting position, direct assembly, side-by-side assembly, see Configuration chapter.

13.2.7 3RW30 36, 37, 38, 46, 47-.BB.. power electronics



Type		3RW3036	3RW3037	3RW3038	3RW3046	3RW3047
Power electronics						
Current carrying capacity rated operating current I_e						
• Acc. to IEC and UL/CSA ¹⁾ , for standalone assembly, AC-53a						
- At 40 °C	A	45	65	72	80	106
- At 50 °C	A	42	58	62.1	73	98
- At 60 °C	A	39	53	60	66	90
Power loss						
• During operation after startup of the motor at uninterrupted rated operat. curr.(40 °C) approx.	W	6	12	15	12	21
• During starting at 300 % $I_M(40 °C)$	W	316	444	500	576	768
Permissible rated motor current and starts per hour at normal starting (class 10)						
- Rated motor curr. $I_M^{(2)}$, ramp-up time 3s	A	45 / 42	63 / 58	72 / 62	80 / 73	106 / 108
- Starts per hour ³⁾	1/h	38 / 38	23 / 23	22 / 22	22 / 22	15 / 15
- Rated motor curr. $I_M^{(2)}$, ramp-up time 4s	A	45 / 42	63 / 58	72 / 62	80 / 73	106 / 98
- Starts per hour ³⁾	1/h	26 / 26	15 / 15	15 / 15	15 / 15	10 / 10

1) Measurement at 60 °C in accordance with UL/CSA not required.

2) At 300 % I_M . $T_{amb} = 40 °C / 50 °C$

3) For intermittent duty S4 with ON time 70 %, $T_{amb} = 40 °C / 50 °C$, vertical standalone assembly. The specified switching frequencies do not apply to automatic mode.

13.2.8 3RW30 main conductor cross-sections

Soft starter	Type		3RW301.	3RW302.	3RW303.	3RW304.	
Conductor cross-sections							
Screw terminals Front clamping point connected 	Main conductors						
	• Solid	mm ²	2 x (1...2.5); 2 x (2.5...6) acc. to IEC 60947	2 x (1...2.5); 2 x (2.5...6) acc. to IEC 60947; max. 1 x 10	2 x (1.5...16)	2 x (2.5...16)	
	• Finely stranded with end sleeve	mm ²	2 x (1.5...2.5); 2 x (2.5...6)	2 x (1...2.5); 2 x (2.5...6)	1 x (0.75...25)	1 x (2.5...35)	
	• Stranded	mm ²	–	–	1 x (0.75...35)	1 x (4...70)	
	• AWG cables	AWG	2 x (16 ... 12)	2 x (16 ... 12)	–	–	
	- Solid or stranded	AWG	2 x (14...10)	2 x (14...10)	1 x (18...2)	1 x (10...2/0)	
	- Stranded	AWG	1 x 8	1 x 8	–	–	
	Rear clamping point connected 	• Solid	mm ²	–	–	2 x (1.5...16)	2 x (2.5...16)
		• Finely stranded with end sleeve	mm ²	–	–	1 x (1.5...25)	1 x (2.5...50)
		• Stranded	mm ²	–	–	1 x (1.5...35)	1 x (10...70)
• AWG cables		AWG	–	–	1 x (16...2)	1 x (10...2/0)	
Both clamping points connected 	• Solid	mm ²	–	–	2 x (1.5...16)	2 x (2.5...16)	
	• Stranded	mm ²	–	–	2 x (1.5...25)	2 x (10...50)	
	• Finely stranded with end sleeve	mm ²	–	–	2 x (1.5...16)	2 x (2.5...35)	
	• AWG cables	AWG	–	–	2 x (16...2)	2 x (10...1/0)	
	- Solid or stranded	AWG	–	–	–	–	
	• Tightening torque	Nm lb.in	2...2.5 18...22	2...2.5 18...22	4.5 40	6.5 58	
Tools		PZ2	PZ2	PZ2	Allen screw 4 mm		
Degree of protection		IP20	IP20	IP20 (terminal compartment IP00)	IP20 (terminal compartment IP00)		
Spring-loaded terminals	Main conductors						
	• Solid	mm ²	1...4	1...10	–	–	
	• Finely stranded with end sleeve	mm ²	1...2.5	1...6; end sleeves, without plastic collar	–	–	
	• AWG cables	AWG	16...14	16...10	–	–	
	- Solid or stranded (finely stranded)	AWG	16...12	1 x 8	–	–	
Tools		DIN ISO 2380-1A0; 5 x 3	DIN ISO 2380-1A0; 5 x 3	–	–		
Degree of protection		IP20	IP20	–	–		
Busbar connections	Main conductors						
	• With cable lug according to DIN 46234 or max. 20 mm wide						
	- Stranded	mm ²	–	–	–	2 x (10...70)	
- Finely-stranded	mm ²	–	–	–	2 x (10...50)		
• AWG cables, solid or stranded	AWG	–	–	–	2 x (7...1/0)		

13.2.9 3RW30 auxiliary conductor cross-sections

Soft starters	Type	3RW301....3RW304.	
Conductor cross-sections			
Auxiliary conductors (1 or 2 conductors can be connected):			
Screw terminals			
• Solid	mm ²	2 x (0.5...2.5)	
• Finely stranded with end sleeve	mm ²	2 x (0.5...1.5)	
• AWG cables			
- Solid or stranded	AWG	2 x (20...14)	
- Finely stranded with end sleeve	AWG	2 x (20...16)	
• Terminal screws			
- Tightening torque	Nm lb.in	0.8...1.2 7...10.3	
Spring-loaded terminals			
• Solid	mm ²	2 x (0.25...2.5)	
• Finely stranded with end sleeve	mm ²	2 x (0.25...1.25)	
• AWG cables, solid or stranded	AWG	2 x (24...14)	

13.2.10 Electromagnetic compatibility according to EN 60947-4-2

	Standard	Parameters
Electromagnetic compatibility according to EN 60947-4-2		
<i>EMC interference immunity</i>		
Electrostatic discharge (ESD)	EN 61000-4-2	±4 kV contact discharge, ±8 kV air discharge
Electromagnetic RF fields	EN 61000-4-3	Frequency range: 80 ... 2000 MHz with 80 % at 1 kHz Degree of severity 3: 10 V/m
Conducted RF interference	EN 61000-4-6	Frequency range: 150 kHz ... 80 MHz with 80 % at 1 kHz Interference 10 V
RF voltages and RF currents on cables		
• Burst	EN 61000-4-4	±2 kV / 5 kHz
• Surge	EN 61000-4-5	±1 kV line to line ±2 kV line to ground
<i>EMC interference emission</i>		
EMC interference field strength	EN 55011	Limit value of Class A at 30 ... 1000 MHz, Limit value of Class B for 3RW302.; 24 V AC/DC
Radio interference voltage	EN 55011	Limit value of Class A at 0.15 ... 30 MHz, Limit value of Class B for 3RW302.; 24 V AC/DC
<i>Radio interference suppression filters</i>		
Degree of noise suppression A (industrial applications)	Not required	
Degree of noise suppression B (applications for residential areas)		
Control voltage		
• 230 V AC/DC	Not available ¹⁾	
• 24 V AC/DC	Not required for 3RW301. and 3RW302; Required for 3RW303. and 3RW304. (see table)	

1) Degree of noise suppression B cannot be obtained through the use of filters as the strength of the electromagnetic field is not attenuated by the filter.

13.2.11 Recommended filters

Soft starter type	Rated current of soft starter	Recommended filter ¹⁾		
		Voltage range 200 to 480 V		
		Filter type	Rated current of filter	Terminals
A	A	mm ²		
3RW3036	45	4EF1512-1AA10 ⇒ B84143B0050R110 (https://www.tdk-electronics.tdk.com/)	50	16
3RW3037	63	4EF1512-2AA10 ⇒ B84143B0066R110 (https://www.tdk-electronics.tdk.com/)	66	25
3RW3038	72	4EF1512-3AA10 ⇒ B84143B0090R110 (https://www.tdk-electronics.tdk.com/)	90	25
3RW3046	80	4EF1512-3AA10 ⇒ B84143B0090R110 (https://www.tdk-electronics.tdk.com/)	90	25
3RW3047	106	4EF1512-4AA10 ⇒ B84143B0120R110 (https://www.tdk-electronics.tdk.com/)	120	50

1) The radio interference suppression filter is used to remove conducted interference in the main circuit. The field-bound emissions meet radio suppression level B. The filter selection applies under standard conditions: 10 starts per hour, start time 4 s at 300% I_e.

13.2.12 Types of coordination

The type of coordination according to which the motor feeder with soft starter is mounted depends on the application-specific requirements. Normally, fuseless mounting (combination of motor starter protector and soft starter) is sufficient.

If type of coordination 2 needs to be fulfilled, semiconductor fuses must be fitted in the motor feeder.

ToC 1 Type of coordination 1 in accordance with IEC 60947-4-1:
The device is defective following a short-circuit failure and therefore unsuitable for further use. (Personnel and equipment must not be put at risk).

ToC 2 Type of coordination 2 in accordance with IEC 60947-4-1:
The device is suitable for further use following a short-circuit failure. (Personnel and equipment must not be put at risk).
The type of coordination only refers to soft starters in conjunction with the stipulated protective device (motor starter protector / fuse), not to additional components in the feeder.

13.2.13 More information on configuration

Catalog IC 10

More information on configuration is available in the catalog (<https://support.industry.siemens.com/cs/ww/en/view/109747945>) from page 6/105 (2025).

13.3 3RW40

13.3.1 Overview

SIRIUS 3RW40 soft starters have all the same advantages as the 3RW30 soft starters.

SIRIUS 3RW40 soft starters are characterized above all by their small space requirements. Integral bypass contacts mean that no power loss has to be taken into account at the power semiconductors (thyristors) after the motor has started up. This cuts down on heat losses, enabling a more compact design and making external bypass circuits superfluous.

At the same time, this soft starter comes with additional integrated functions such as settable current limiting, motor overload and intrinsic device protection, and optional thermistor motor protection. The higher the motor rating, the more important these functions become because they make it unnecessary to purchase and install protection equipment (such as overload relays).

Internal intrinsic device protection prevents thermal overloading of the thyristors and the power unit defects this can cause. As an option, the thyristors can also be protected against short-circuiting with semiconductor fuses.

Thanks to integrated status and fault monitoring, this compact soft starter offers many different diagnostics options. Up to four LEDs and relay outputs permit differentiated monitoring and diagnostics of the operating mechanism by indicating the operating state as well as for example mains or phase failure, missing load, non-permissible tripping time/CLASS setting, thermal overloading or device faults.

Soft starters rated up to 250 kW (at 400 V) can be supplied for standard applications in three-phase systems. Extremely small sizes, low power losses, and simple commissioning are just three of the many advantages of the SIRIUS 3RW40 soft starters.

"Increased safety" type of protection Ex eb according to ATEX Directive 2014/34/EU

The 3RW40 soft starters are suitable for starting explosion-proof motors with the "increased safety" type of protection Ex eb.

Note

The rated motor current is extremely important when selecting a soft starter.

Refer to the information about selecting soft starters in chapter Configuration (Page 83).

Conditions for normal starting (CLASS 10):

Max. starting time 10 s, current limitation 300%, 5 starts/hour, ON time 30%, standalone assembly, max. installation altitude 1000 m / 3280 ft, ambient temperature kW 40 °C / 104 °F. In the event of deviating conditions or increased switching frequency, it may be necessary to choose a larger device. For information about the rated currents for ambient temperatures above 40 °C, refer to chapter 3RW40 power electronics (Page 137).

13.3.2 3RW40 2., 3., 4. control electronics

Type	3RW402.		3RW403., 3RW404.	
Control electronics				
Rated values	Terminal			
Rated control supply voltage	A1 / A2	V	24	110 ... 230
• Tolerance		%	±20	-15 / +10
Rated control supply current				
• STANDBY		mA	< 150	< 50
• During pickup		mA	< 200	< 100
• ON without fan		mA	< 250	< 50
• ON with fan		mA	< 300	< 70
Rated frequency		Hz	50 / 60	
• Tolerance		%	±20	
Control inputs				
IN			ON / OFF	
Rated operational current				
• A C		mA	approx. 12	3 / 6
• D C		mA	approx. 12	1,5 / 3
Relay outputs				
Output 1	ON / RUN mode ¹⁾	13 / 14	Operating indication (NO)	
Output 2	BYPASSED	23 / 24	Bypass indication (NO)	
Output 3	OVERLOAD / FAILURE	95 / 96 / 98	Overload / fault indication (NC/NO)	
Thermistor motor protection (PTC binary)				
Total cold resistance		kOhm	≤ 1,5	
Response value		kOhm	3,4 ... 3,8	
Return value		kOhm	1,5 ... 1,65	
Cable lengths, cable cross sections			2 x 250 m: 2.5 mm ²	
			2 x 150 m: 1.5 mm ²	
			2 x 50 m: 0.5 mm ²	
Rated operational current		A	3 AC-15 / AC-14 at 230 V,	
		A	1 DC-13 at 24 V	
Protection against overvoltages			Protection by means of varistor through contact	
Short-circuit protection			4 A operational class gL / gG;	
			6 A quick (fuse not included in scope of supply)	

1) Factory setting: ON Mode.

13.3.3 3RW40 2., 3., 4. control electronics

Type	3RW402., 3RW403., 3RW404.			
Control electronics				
Operating indications	LED	DEVICE	STATE/BYPASSED/FAILURE	OVERLOAD
Off		Green	Off	Off
Start		Green	Green flashing	Off
Bypass		Green	Green	Off
Stop		Green	Green flashing	Off
Alarm signals				
Impermissible I _e / CLASS setting		Green	Not relevant	Red flashing
Start inhibited / thyristors too hot		Yellow flashing	Not relevant	Off
Fault signals				
• 24 V: U < 0.75 x U _s or U > 1.25 x U _s		Off	Red	Off
• 110 ... 230 V: U < 0.75 x U _s or U > 1.15 x U _s		Off	Red	Off
Impermissible I _e / CLASS setting for edge 0→1 on input IN		Green	Red	Red flashing
Motor protection tripping (overload thermistor)		Green	Off	Red
Thermistor defective (wire breakage, short-circuit)		Green	Off	Red flickering
Thermal overload of the thyristors		Yellow	Red	Off
Missing mains voltage, phase failure / missing load		Green	Red	Off
Device fault		Red	Red	Off

13.3 3RW40

13.3.4 3RW40 protection functions

Type	3RW40..		Factory default
Protection functions			
Motor protection functions			
Trips in the event of			
Trip class to IEC 60947-4-1	Class	Thermal overloading of the motor 10 / 15 / 20	10
Phase failure sensitivity	%	> 40	
Overload warning		No	
Thermistor protection according to IEC 60947-8, type A / IEC 60947-5-1		Yes ¹⁾	
Reset option after tripping		Manual / automatic / remote reset ²⁾ (MAN / AUTO / REMOTE ²⁾)	
Recovery time	min	5	
Device protection functions			
Trips in the event of			
Reset option after tripping		Thermal overloading of the thyristors or bypass ³⁾ Manual / automatic / remote reset ²⁾ (MAN / AUTO / REMOTE ²⁾)	
Recovery time			
• During overloading of the thyristors	s	30	
• During overloading of the bypass	s	60	

1) Optional up to size S3 (device version).

2) Integrated remote reset (REMOTE) available only for 3RW402. to 3RW404.; remote reset with accessory module 3RU19 available for 3RW405. and 3RW407.

3) Bypass protection up to size S3.

13.3.5 3RW40 control times and parameters

Type	3RW40..		Factory default
Control times and parameters			
Control times			
Closing delay (with connected control voltage)	ms	< 50	
Closing delay (automatic / line contactor mode)	ms	< 300	
Recovery time (closing command during active stop)	ms	100	
Mains failure bridging time			
Control supply voltage	ms	50	
Mains / phase failure response time			
Load circuit			
• During starting and stopping	s	1	
• During bypass	s	5	
Reclosing lockout after overload trip			
Motor protection trip	min	5	
Device protection trip			
• During overloading of the thyristors	s	30	
• During overloading of the bypass	s	60	
Start parameters			
Starting time	s	0 ... 20	7,5
Start voltage	%	40 ... 100	40
Starting current limiting		1.3 ... 5 x I _e / max ¹⁾	5 x I _e
Stop parameters			
Stopping time	s	0 ... 20	0
Reset mode parameters (for motor / device protection trip)			
Manual reset	LED	Off	Off
Automatic reset	LED	Yellow	
Remote reset (REMOTE)	LED	Green	
Ramp-up detection			
Yes			
Operating mode output 13 / 14			
Rising edge at	Start command		
Falling edge at	Off command End of stopping	ON RUN	ON

1) Product version E07 and higher (for 3RW40 size S0 to S3) or product version E11 and higher (for 3RW40 S6 to S12)

13.3.6 3RW40 power electronics

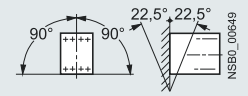
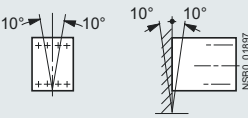
Type		3RW402.-.B.4, 3RW403.-.B.4, 3RW404.-.B.4	3RW402.-.B.5, 3RW403.-.B.5, 3RW404.-.B.5
Power electronics			
Rated operational voltage	V AC	200 ... 480	400 ... 600
Tolerance	%	-15 / +10	-15 / +10
Maximum thyristor blocking voltage	V AC	1600	
Rated frequency	Hz	50/60	
Tolerance	%	±10	
Continuous duty at 40 °C (% of I _e)		115	
Minimum load (% of minimum selectable rated motor current I _M)	%	20 (at least 2 A)	
Maximum cable length between soft starter and motor	m	300	
Permissible installation altitude	m	5000 (Derating from 1000, see characteristic curves); higher on request	
Permissible mounting position		<ul style="list-style-type: none"> • With auxiliary fan (for 3RW402. ... 3RW404.)  <ul style="list-style-type: none"> • Without auxiliary fan (for 3RW402. ... 3RW404.) 	
Permissible ambient temperature			
Operation	°C	-25 ... +60; (derating from +40)	
Storage	°C	-40 ... +80	
Degree of protection		IP20 for 3RW402.; IP00 for 3RW403. and 3RW404.	

13.3 3RW40

13.3.7 3RW40 24, 26, 27, 28 power electronics

Type		3RW4024	3RW4026	3RW4027	3RW4028
Power electronics					
Current carrying capacity rated operational current I_e					
• According to IEC and UL / CSA ¹⁾ , for single assembly, AC-53a					
- at 40 °C	A	12.5	25.3	32.2	38
- at 50 °C	A	11	23	29	34
- at 60 °C	A	10	21	26	31
Minimum settable rated motor current I_M for motor overload protection					
	A	5	10	17	23
Power loss					
• During operation after run-up at uninterrupted rated operational current (40 °C) approx.					
	W	2	8	13	19
• During start-up with set current limitation to 300 % I_M (40 °C)					
	W	68	188	220	256
Permissible rated motor current and starts per hour					
• For normal starting (class 10)					
- Rated motor current $I_M^{(2)}$, run-up time 3 s	A	12.5 / 11	25 / 23	32 / 29	38 / 34
- Starts per hour ³⁾	1/h	50 / 50	23 / 23	23 / 23	19 / 19
- Rated motor current $I_M^{(2)}$, run-up time 4 s	A	12.5 / 11	25 / 23	32 / 29	38 / 34
- Starts per hour ³⁾	1/h	36 / 36	15 / 15	16 / 16	12 / 12
• For heavy-duty starting (class 15)					
- Rated motor current $I_M^{(2)}$, run-up time 4.5 s	A	11 / 10	23 / 21	30 / 27	34 / 31
- Starts per hour ³⁾	1/h	49 / 49	21 / 21	18 / 18	18 / 18
- Rated motor current $I_M^{(2)}$, run-up time 6 s	A	11 / 10	23 / 21	30 / 27	34 / 31
- Starts per hour ³⁾	1/h	36 / 36	14 / 14	13 / 13	13 / 13
• For heavy-duty starting (class 20)					
- Rated motor current $I_M^{(2)}$, run-up time 6 s	A	10 / 9	21 / 19	27 / 24	31 / 28
- Starts per hour ³⁾	1/h	47 / 47	21 / 21	20 / 20	18 / 18
- Rated motor current $I_M^{(2)}$, run-up time 8 s	A	10 / 9	21 / 19	27 / 24	31 / 28
- Starts per hour ³⁾	1/h	34 / 34	15 / 15	14 / 14	13 / 13

- 1) Measurement at 60 °C acc. to UL / CSA not required.
- 2) Current limitation on soft starter set to 300 % I_M . $T_a = 40 °C / 50 °C$. Maximum settable rated motor current I_M , depending on the CLASS setting.
- 3) For intermittent duty S4 with ON time $OT = 30 %$, $T_a = 40 °C / 50 °C$, stand-alone assembly vertical. The specified switching frequencies do not apply to automatic mode. Factors for permissible switching frequency for different mounting position, direct, side-by-side mounting, and use of an optional additional fan, see chapter Configuration.

13.3.8 3RW40 36, 37, 38, 46, 47 power electronics



Type	3RW4036	3RW4037	3RW4038	3RW4046	3RW4047	
Power electronics						
Current carrying capacity rated operational current I_g						
• According to IEC and UL/CSA ¹⁾ , for single assembly, AC-53a						
- at 40 °C	A	45	63	72	80	106
- at 50 °C	A	42	58	62,1	73	98
- at 60 °C	A	39	53	60	66	90
Minimum settable rated motor current I_M for motor overload protection						
	A	23	26	35	43	46
Power loss						
• During operation after run-up at uninterrupted rated operational current (40 °C) approx.						
	W	6	12	15	12	21
• During start-up with set current limitation to 300 % I_M (40 °C)						
	W	316	444	500	576	768
Permissible rated motor current and starts per hour						
• For normal starting (class 10)						
- Rated motor current $I_M^{(2)}$, run-up time 3 s	A	45 / 42	63 / 58	72 / 62	80 / 73	106 / 98
- Starts per hour ³⁾	1/h	38 / 38	23 / 23	22 / 22	22 / 22	15 / 15
• For heavy-duty starting (class 15)						
- Rated motor current $I_M^{(2)}$, run-up time 4 s	A	45 / 42	63 / 58	72 / 62	80 / 73	106 / 98
- Starts per hour ³⁾	1/h	26 / 26	15 / 15	15 / 15	15 / 15	10 / 10
• For heavy-duty starting (class 15)						
- Rated motor current $I_M^{(2)}$, run-up time 4.5 s	A	42 / 38	50 / 46	56 / 52	70 / 64	84 / 77
- Starts per hour ³⁾	1/h	30 / 30	34 / 34	34 / 34	24 / 24	23 / 23
• For heavy-duty starting (class 20)						
- Rated motor current $I_M^{(2)}$, run-up time 6 s	A	42 / 38	50 / 46	56 / 52	70 / 64	84 / 77
- Starts per hour ³⁾	1/h	21 / 21	24 / 24	24 / 24	16 / 16	17 / 17
• For heavy-duty starting (class 20)						
- Rated motor current $I_M^{(2)}$, run-up time 6 s	A	38 / 34	46 / 42	50 / 46	64 / 58	77 / 70
- Starts per hour ³⁾	1/h	30 / 30	31 / 31	34 / 34	23 / 23	23 / 23
• For heavy-duty starting (class 20)						
- Rated motor current $I_M^{(2)}$, run-up time 8 s	A	38 / 34	46 / 42	50 / 46	64 / 58	77 / 70
- Starts per hour ³⁾	1/h	21 / 21	22 / 22	24 / 24	16 / 16	16 / 16

1) Measurement at 60 °C acc. to UL / CSA not required.

2) Current limitation on soft starter set to 300 % I_M . $T_a = 40\text{ °C} / 50\text{ °C}$
Maximum settable rated motor current I_M , depending on the CLASS-setting.

3) For intermittent duty S4 with ON time $OT = 30\%$, $T_a = 40\text{ °C} / 50\text{ °C}$, stand-alone assembly vertical. The specified switching frequencies do not apply to automatic mode. Factors for permissible switching frequency for different mounting position, direct, side-by-side mounting, and use of an optional additional fan, see chapter Configuration.

13.3.9 3RW40 2., 3., 4. main conductor cross-sections

Soft starters	Type		3RW402.	3RW403.	3RW404.
Conductor cross-sections					
Screw terminals Front clamping point connected 	Main conductors • Solid • With end sleeve • Stranded • AWG cables - Solid - Solid or stranded - Stranded • Solid • With end sleeve • Stranded • AWG cables - Solid or stranded • Solid • With end sleeve • Stranded • AWG cables - Solid or stranded • Tightening torque Tools Degree of protection	mm ²	2 x (1.5 ... 2.5); 2 x (2.5 ... 6) according to IEC 60947; max. 1 x 10	2 x (1.5 ... 16)	2 x (2.5 ... 16)
		mm ²	2 x (1.5 ... 2.5); 2 x (2.5 ... 6)	1 x (0.75 ... 25)	1 x (2.5 ... 35)
		mm ²	–	1 x (0.75 ... 35)	1 x (4 ... 70)
		AWG	2 x (16 ... 12)	–	–
		AWG	2 x (14 ... 10)	1 x (18 ... 2)	2 x (10 ... 1/0)
		AWG	1 x 8	–	–
		mm ²	–	2 x (1.5 ... 16)	2 x (2.5 ... 16)
		mm ²	–	1 x (1.5 ... 25)	1 x (2.5 ... 50)
		mm ²	–	1 x (1.5 ... 35)	1 x (10 ... 70)
		AWG	–	1 x (16 ... 2)	2 x (10 ... 1/0)
		mm ²	–	2 x (1.5 ... 16)	2 x (2.5 ... 16)
		mm ²	–	2 x (1.5 ... 16)	2 x (2.5 ... 35)
		mm ²	–	2 x (1.5 ... 25)	2 x (10 ... 50)
		AWG	–	2 x (16 ... 2)	1 x (10 ... 2/0)
		Nm lb.in	2 ... 2.5 18 ... 22	4.5 40	6.5 58
PZ2	PZ2	Allen screw 4 mm			
IP20	IP20 (terminal compartment IP00)	IP20 (terminal compartment IP00)			
Spring-loaded terminals 	Main conductors • Solid • Finely stranded with end sleeve • AWG cables - Solid or stranded (finely stranded) - Stranded Tools Degree of protection	mm ²	1 ... 10	–	–
		mm ²	1 ... 6 end sleeves without plastic collar	–	–
		AWG	16 ... 10	–	–
		AWG	1 x 8	–	–
		DIN ISO 2380-1A0; 5 x 3	–	–	
		IP20	–	–	
Busbar connections 	Main conductors • With cable lug according to DIN 46234 or 20 mm wide - Stranded - Finely-stranded • AWG cables, solid or stranded	mm ²	–	–	2 x (10 ... 70)
		mm ²	–	–	2 x (10 ... 50)
		AWG	–	–	2 x (7 ... 1/0)
		–	–	–	–

13.3.10 3RW40 .. auxiliary conductor cross-sections

Arrancador suave	Tipo	3RW40..	
Secciones de conductor			
Conductores auxiliares (aptos para 1 ó 2 conductores)			
Bornes de tornillo			
• Monofilares	mm ²	2 x (0,5 ... 2,5)	
• Alma flexible con puntera	mm ²	2 x (0,5 ... 1,5)	
• Cables AWG			
- Monofilares o multifilares	AWG	2 x (20 ... 14)	
- Alma flexible con puntera	AWG	2 x (20 ... 16)	
• Tornillos de conexión			
- Par de apriete	Nm lb.in	0,8 ... 1,2 7 ... 10,3	
Bornes de resorte			
• Monofilares	mm ²	2 x (0,25 ... 2,5)	
- 3RW402. ... 3RW404.	mm ²	2 x (0,25 ... 1,5)	
- 3RW405., 3RW407.	mm ²	2 x (0,25 ... 1,5)	
• Alma flexible con puntera	mm ²	2 x (0,25 ... 1,5)	
• Cables AWG, monofilares o multifilares	AWG	2 x (24 ... 14) con 3RW402. ... 3RW404.;	

13.3.11 Electromagnetic compatibility according to EN 60947-4-2

	Standard	Parameters
Electromagnetic compatibility according to EN 60947-4-2		
EMC interference immunity		
Electrostatic discharge (ESD)	EN 61000-4-2	± 4 kV contact discharge, ± 8 kV air discharge
Electromagnetic RF fields	EN 61000-4-3	Frequency range: 80 to 1000 MHz with 80% at 1 kHz Degree of severity 3: 10 V/m
Conducted RF interference	EN 61000-4-6	Frequency range: 150 kHz...80 MHz with 80% at 1 kHz Interference 10 V
RF voltages and RF currents on cables		
• Burst	EN 61000-4-4	± 2 kV / 5 kHz
• Surge	EN 61000-4-5	±1 kV line to line ±2 kV line to ground
EMC interference emission		
EMC interference field strength	EN 55011	Limit value of Class A at 30...1000 MHz, Limit value of Class B for 3RW402.; 24 V AC/DC
Radio interference voltage	EN 55011	Limit value of Class A at 0.15...30 MHz, Limit value of Class B for 3RW402.; 24 V AC/DC
Radio interference suppression filters		
Degree of noise suppression A (industrial applications)	Not required	
Degree of noise suppression B (applications for residential areas)		
Control voltage		
• 110...230 V AC/DC	Not available ¹⁾	
• 115/230 V AC	Not available ¹⁾	
• 24 V AC/DC	Not required for 3RW402.; Required for 3RW403. and 3RW404.	

1) Degree of noise suppression B cannot be obtained through the use of filters as the strength of the electromagnetic field is not attenuated by the filter.

13.3.12 Recommended filters

Soft starter type	Rated current of soft starter	Recommended filter ¹⁾		
		Voltage range 200 ... 480 V		
		Filter type	Rated current of filter	Connecting terminals
A	A	mm ²		
3RW4036	45	4EF1512-1AA10 ⇒ B84143B0050R110 (https://www.tdk-electronics.tdk.com/)	50	16
3RW4037	63	4EF1512-2AA10 ⇒ B84143B0066R110 (https://www.tdk-electronics.tdk.com/)	66	25
3RW4038	72	4EF1512-3AA10 ⇒ B84143B0090R110 (https://www.tdk-electronics.tdk.com/)	90	25
3RW4046	80	4EF1512-3AA10 ⇒ B84143B0090R110 (https://www.tdk-electronics.tdk.com/)	90	25
3RW4047	106	4EF1512-4AA10 ⇒ B84143B0120R110 (https://www.tdk-electronics.tdk.com/)	120	50

1) The interference suppression filter is used to remove conducted interference in the main circuit. The field-conducted emissions meet radio suppression level B. The filter selection applies under standard conditions: 10 starts per hour, start time 4 s at 300% I_e.

13.3.13 Types of coordination

The type of coordination according to which the motor feeder with soft starter is mounted depends on the application-specific requirements. Normally, fuseless mounting (combination of motor starter protector and soft starter) is sufficient. If type of coordination 2 needs to be fulfilled, semiconductor fuses must be fitted in the motor feeder.

- ToC 1 Type of coordination 1 in accordance with IEC 60947-4-1:
The device is defective following a short-circuit failure and therefore unsuitable for further use (personnel and equipment must not be put at risk).
- ToC 2 Type of coordination 2 in accordance with IEC 60947-4-1:
The device is suitable for further use following a short-circuit failure (personnel and equipment must not be put at risk).
The type of coordination only refers to soft starters in conjunction with the stipulated protective device (motor starter protector / fuse), not to additional components in the feeder.

13.3.14 More information on configuration

Catalog IC 10

You will find more information on configuration in the catalog (<https://support.industry.siemens.com/cs/ww/en/view/109747945>) from page 6/93 (2025).

13.3.15 Motor protection tripping characteristics for 3RW40 (with symmetry)

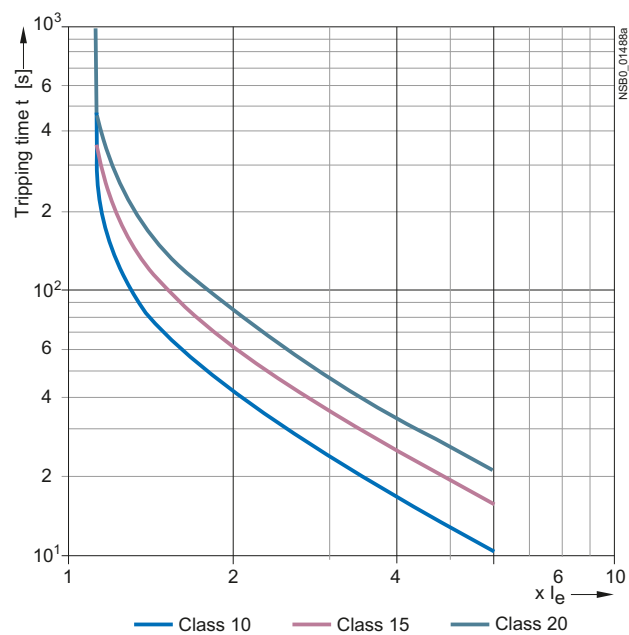

13.3.16 Motor protection tripping characteristics for 3RW40 (with asymmetry)

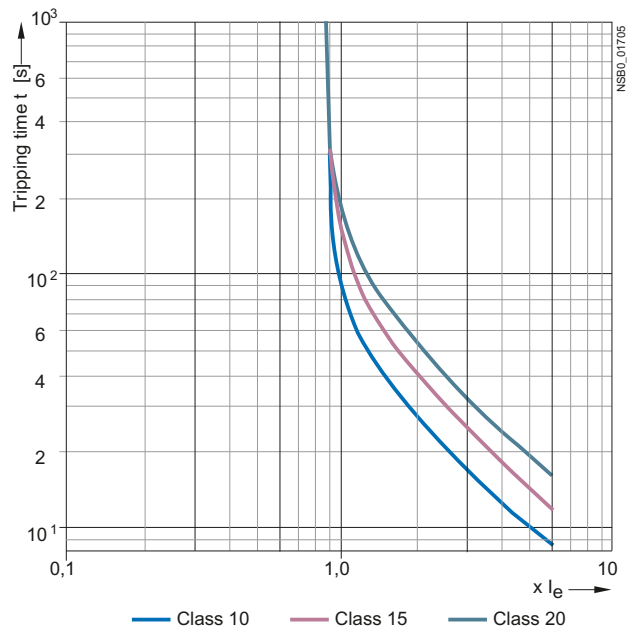

Dimension drawings

14.1 CAx data in the Siemens SiePortal

You can find CAx data for the product in the SiePortal (<https://support.industry.siemens.com/cs/ww/en/ps/25247/td>).

1. Enter the article number of the desired device in the "Products" field.
2. Click the "CAx data" link in the result.

Typical circuit diagrams

15.1 Typical circuit for the optional thermistor motor protection evaluation

A thermistor motor protection evaluation function is optionally available for the 24 V AC/DC control voltage version of the 3RW40 2 to 3RW40 4.

Note

If a thermistor is connected (PTC type A or Klixon), you must remove the copper jumper between terminals T11/T21 and T22.

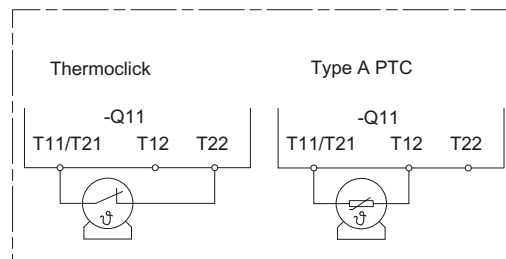

Figure 15-1 Optional thermistor motor protection evaluation

15.2 Control by pushbutton

15.2.1 Control of the 3RW30 by pushbutton

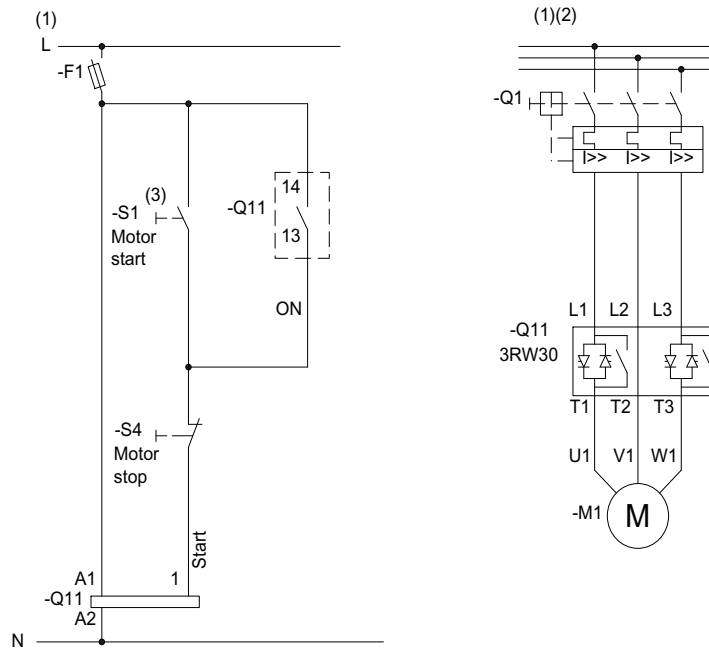

Figure 15-2 Wiring of the 3RW30 control and main circuits

(1) For permissible main and control voltage values (dependent on article number), refer to chapter Technical data (Page 125).

(2) Alternatively, the motor feeder can be assembled as a fuseless or fused version with type of coordination 1 or 2. For the assignment of fuses and switching devices, refer to chapter Technical data (Page 125)

⚠ WARNING

(3) Automatic restart. Can result in death, serious injury, or property damage.

Faults caused by incorrect control voltage, a missing load, or a phase failure (refer to chapter 3RW30: LEDs (Page 57)) are automatically reset when the system returns to normal. An automatic restart is initiated and the 3RW restarted if a start command is present at the input. If you do not want the motor to start automatically, you must integrate suitable additional components, e.g. phase failure or load monitoring devices, into the control and main circuits.

15.2.2 Control of the 3RW40 by pushbutton

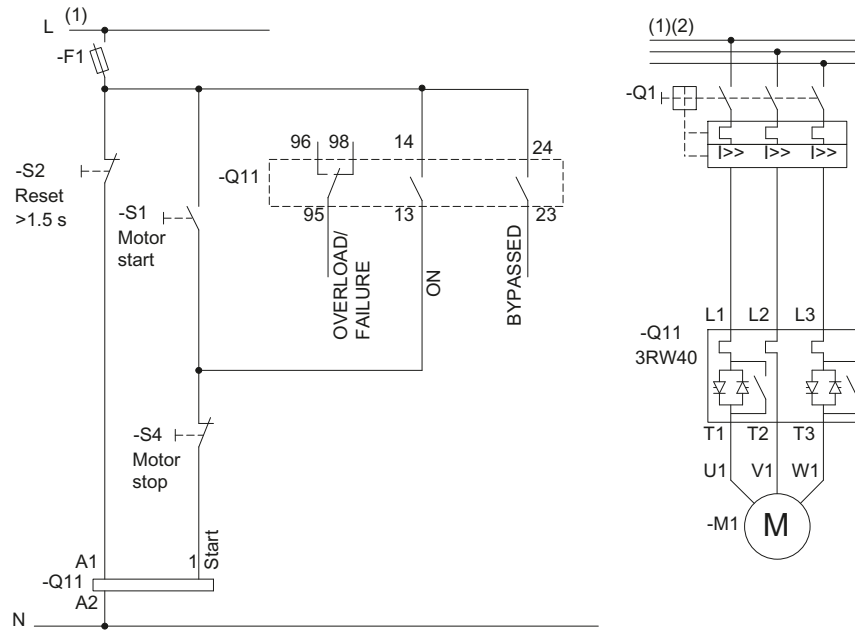

Figure 15-3 Wiring of the 3RW402 - 3RW404 control circuit and 3RW402 - 3RW404 main circuit

(1) For permissible main and control voltage values (dependent on article number), refer to chapter Technical data (Page 125).

(2) Alternatively, the motor feeder can be assembled as a fuseless or fused version with type of coordination 1 or 2. For the assignment of fuses and switching devices, refer to chapter Technical data (Page 125)

For the optional thermistor motor protection evaluation, refer to Typical circuit for the optional thermistor motor protection evaluation (Page 147)

15.3 Control by switch

15.3.1 Control of the 3RW30 by switch

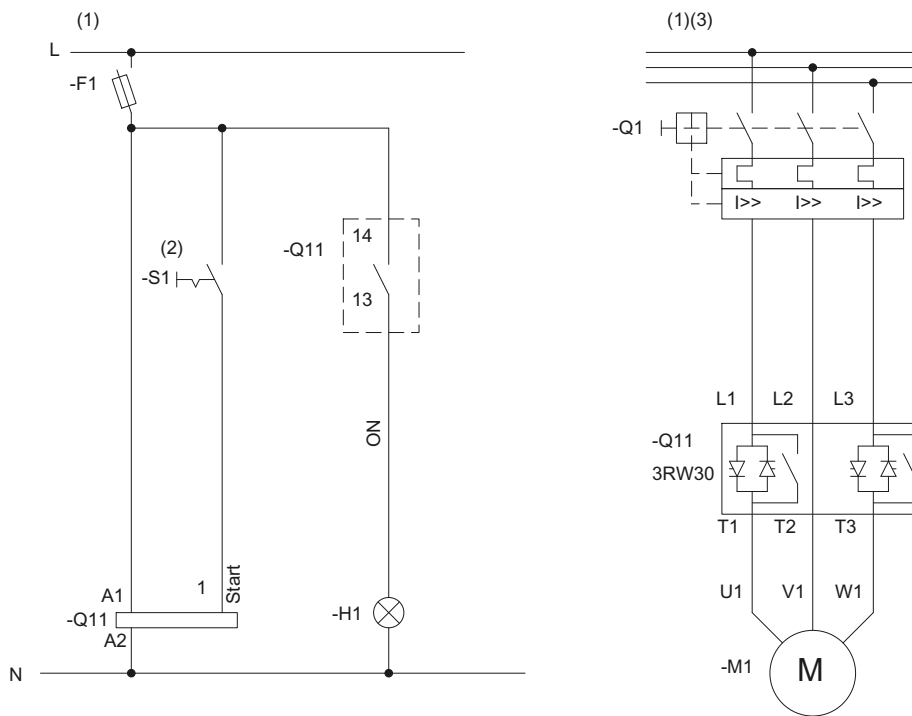

Figure 15-4 Wiring of the control and main circuits

(1) For permissible main and control voltage values (dependent on article number), refer to chapter Technical data (Page 125).

⚠ WARNING

(2) Automatic restart. Can result in death, serious injury, or property damage.

Faults caused by incorrect control voltage, a missing load, or a phase failure (refer to chapter 3RW30: LEDs (Page 57)) are automatically reset when the system returns to normal. An automatic restart is initiated and the 3RW restarted if a start command is present at the input. If you do not want the motor to start automatically, you must integrate suitable additional components, e.g. phase failure or load monitoring devices, into the control and main circuits.

(3) Alternatively, the motor feeder can be assembled as a fuseless or fused version with type of coordination 1 or 2. For the assignment of fuses and switching devices, refer to chapter Technical data (Page 125).

15.3.2 Control of the 3RW40 by switch

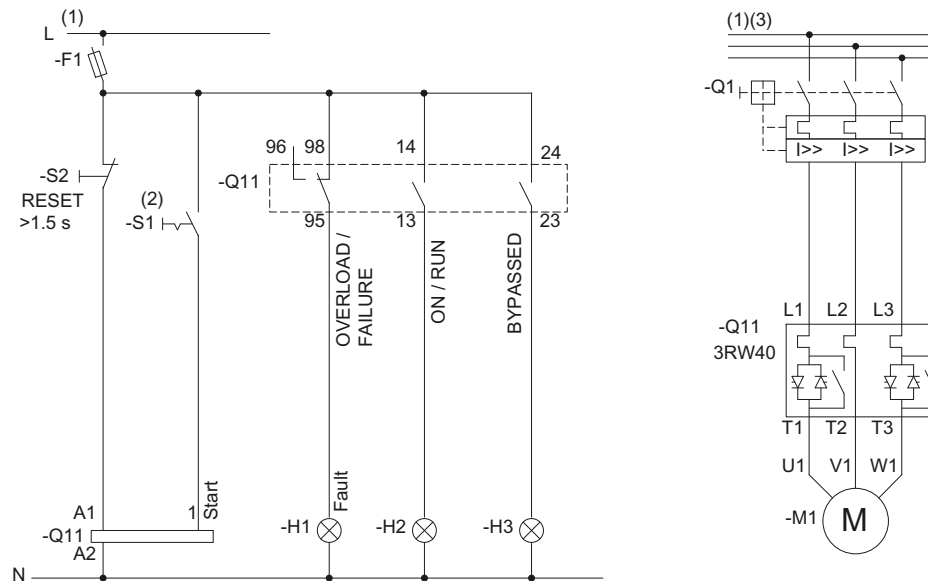

Figure 15-5 Wiring of the 3RW402 - 3RW404 control circuit and 3RW402 - 3RW404 main circuit

(1) For permissible main and control voltage values (dependent on article number), refer to chapter Technical data (Page 125).

⚠ WARNING

(2) Automatic restart. Can result in death, serious injury, or property damage.

The start command (e.g. issued by the PLC or switch S1) must be reset prior to issuing a RESET command because the motor attempts to restart again automatically following this RESET command if a start command is still present. This particularly applies if the motor protection has tripped. For safety reasons, you are advised to integrate the group fault output (terminals 95 and 96) in the controller.

(3) Alternatively, the motor feeder can be assembled as a fuseless or fused version with type of coordination 1 or 2. For the assignment of fuses and switching devices, refer to chapter Technical data (Page 125).

For the optional thermistor motor protection evaluation, refer to Typical circuit for the optional thermistor motor protection evaluation (Page 147).

15.4 Control in automatic mode

15.4.1 Control of the 3RW30 in automatic mode

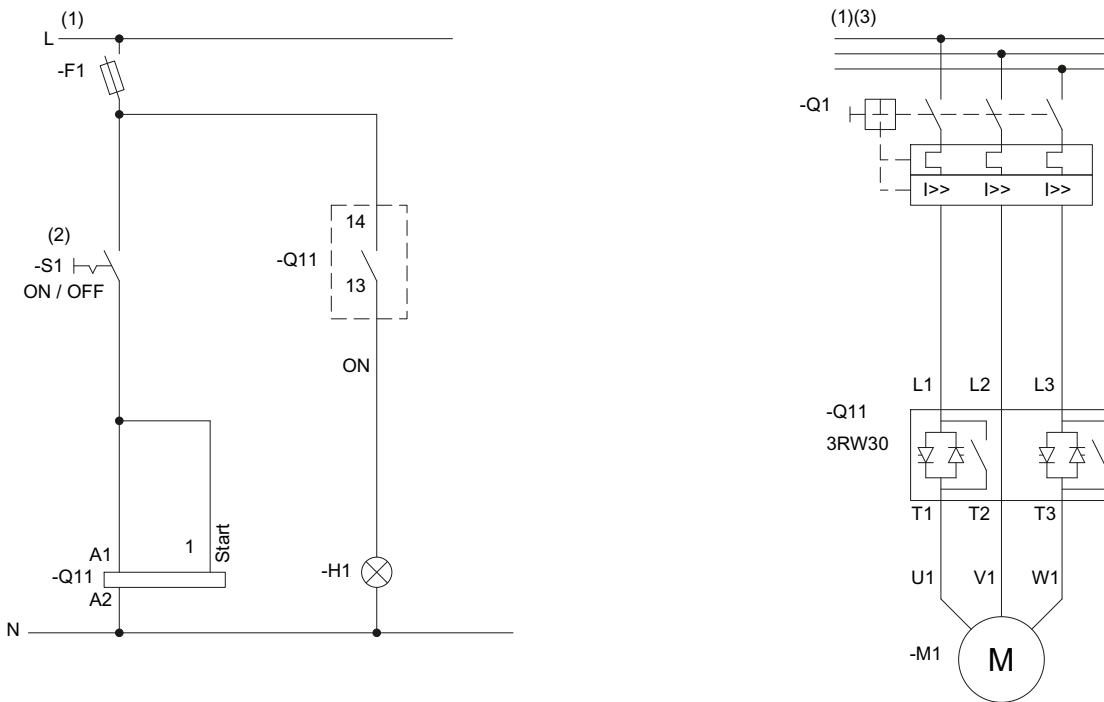

Figure 15-6 Wiring of the 3RW30 control and main circuits

(1) For permissible main and control voltage values (dependent on article number), refer to chapter Technical data (Page 125).

! WARNING

(2) Automatic restart. Can result in death, serious injury, or property damage.

Faults caused by incorrect control voltage, a missing load, or a phase failure (refer to chapter 3RW30: LEDs (Page 57)) are automatically reset when the system returns to normal. An automatic restart is initiated and the 3RW restarted if a start command is present at the input. If you do not want the motor to start automatically, you must integrate suitable additional components, e.g. phase failure or load monitoring devices, into the control and main circuits.

(3) Alternatively, the motor feeder can be assembled as a fuseless or fused version with type of coordination 1 or 2. For the assignment of fuses and switching devices, refer to chapter Technical data (Page 125).

15.4.2 Control of the 3RW40 in automatic mode

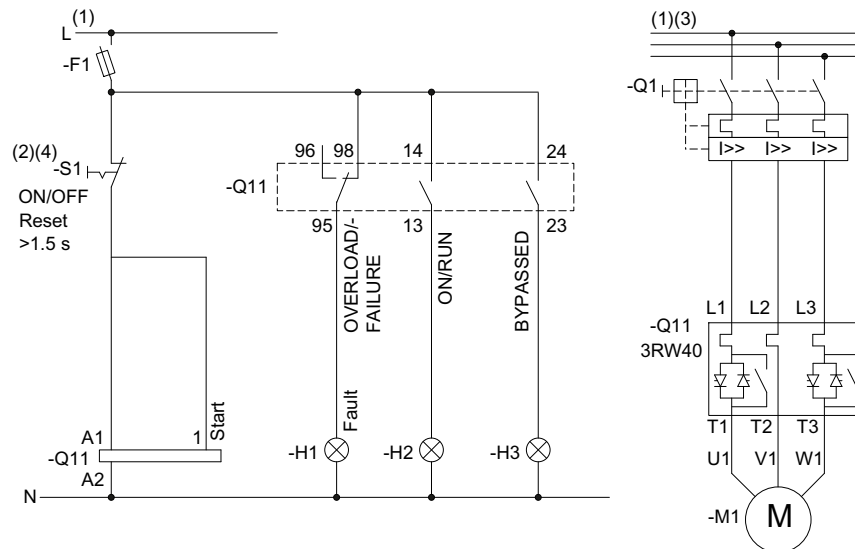

Figure 15-7 Wiring of the 3RW402 - 3RW404 control circuit and 3RW402 - 3RW404 main circuit

(1) For permissible main and control voltage values (dependent on article number), refer to chapter Technical data (Page 125).

WARNING

(2) Automatic restart. Can result in death, serious injury, or property damage.

The start command (e.g. issued by the PLC or switch S1) must be reset prior to issuing a RESET command because the motor attempts to restart again automatically following this RESET command if a start command is still present. This particularly applies if the motor protection has tripped. For safety reasons, you are advised to integrate the group fault output (terminals 95 and 96) in the controller.

(3) Alternatively, the motor feeder can be assembled as a fuseless or fused version with type of coordination 1 or 2. For the assignment of fuses and switching devices, refer to chapter Technical data (Page 125).

Note

(4) Idle time until restart.

Owing to the intrinsic protection (3RW), an idle time of at least five minutes must be allowed prior to restarting if the device is switched on and off by means of the control voltage under field conditions.

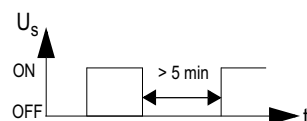

15.4 Control in automatic mode

For the optional thermistor motor protection evaluation, refer to Typical circuit for the optional thermistor motor protection evaluation (Page 147)

15.5 Control by PLC

15.5.1 Control of the 3RW30 with 24 V DC by PLC

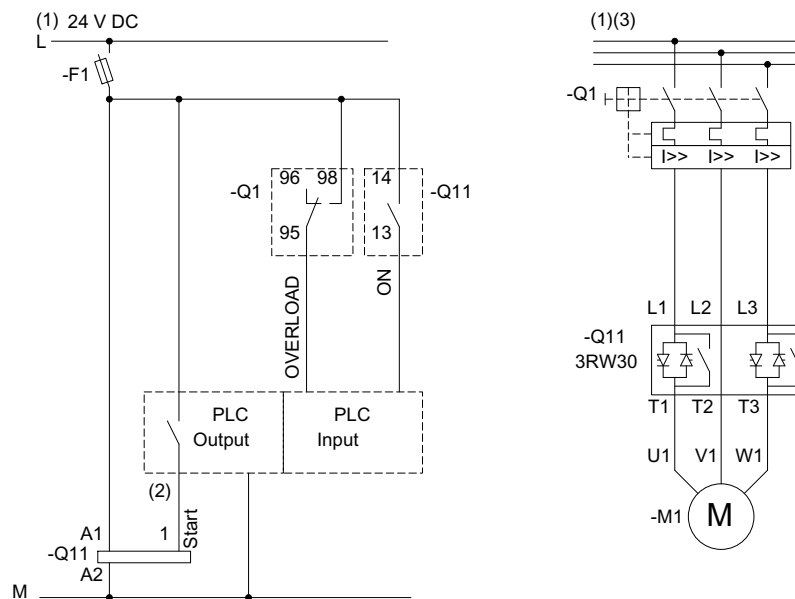

Figure 15-8 Wiring of the 3RW30 control and main circuits

(1) For permissible main and control voltage values (dependent on article number), refer to chapter Technical data (Page 125).

⚠ WARNING

(2) Automatic restart. Can result in death, serious injury, or property damage.

Faults caused by incorrect control voltage, a missing load, or a phase failure (refer to chapter 3RW30: LEDs (Page 57)) are automatically reset when the system returns to normal. An automatic restart is initiated and the 3RW restarted if a start command is present at the input. If you do not want the motor to start automatically, you must integrate suitable additional components, e.g. phase failure or load monitoring devices, into the control and main circuits.

(3) Alternatively, the motor feeder can be assembled as a fuseless or fused version with type of coordination 1 or 2. For the assignment of fuses and switching devices, refer to chapter Technical data (Page 125).

15.5.2 Control of the 3RW40 by PLC

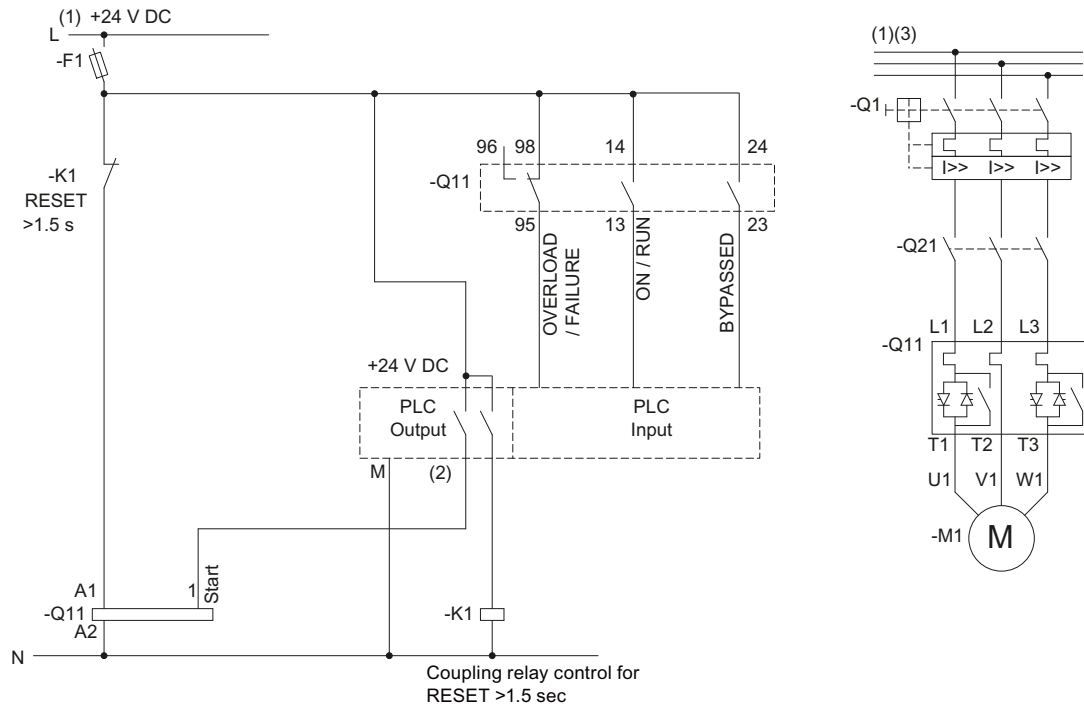

Figure 15-9 Wiring of 3RW402 - 3RW404 control circuit (with 24 V control voltage) and 3RW402 - 3RW404 main circuit

(1) For permissible main and control voltage values (dependent on article number), refer to chapter Technical data (Page 125).

WARNING

(2) Automatic restart. Can result in death, serious injury, or property damage.

The start command (e.g. issued by the PLC or switch S1) must be reset prior to issuing a RESET command because the motor attempts to restart again automatically following this RESET command if a start command is still present. This particularly applies if the motor protection has tripped. For safety reasons, you are advised to integrate the group fault output (terminals 95 and 96) in the controller.

(3) Alternatively, the motor feeder can be assembled as a fuseless or fused version with type of coordination 1 or 2. For the assignment of fuses and switching devices, refer to chapter Technical data (Page 125).

For the optional thermistor motor protection evaluation, refer to Typical circuit for the optional thermistor motor protection evaluation (Page 147).

15.6 Control with an optional main / line contactor

15.6.1 Control of the 3RW30 with a main contactor

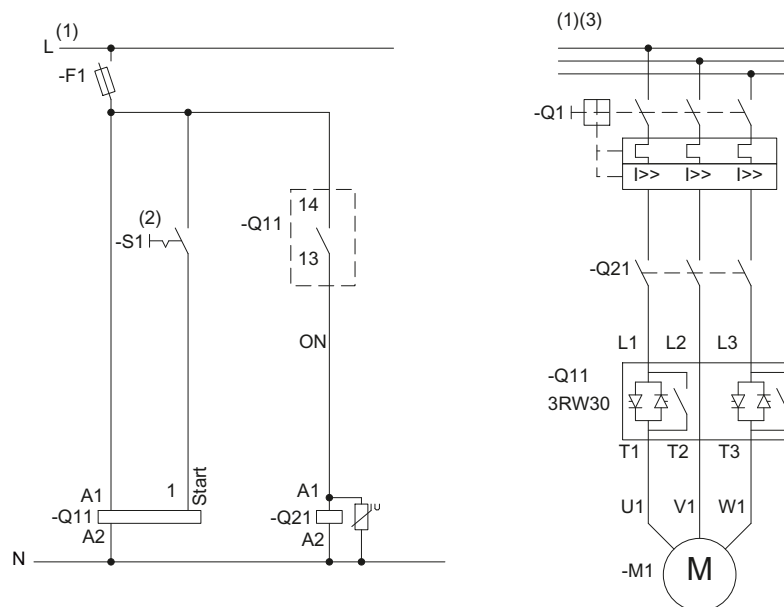

Figure 15-10 Wiring of the 3RW30 control and main circuits

(1) For permissible main and control voltage values (dependent on article number), refer to chapter Technical data (Page 125).

⚠ WARNING

(2) Automatic restart. Can result in death, serious injury, or property damage.

Faults caused by incorrect control voltage, a missing load, or a phase failure (refer to chapter 3RW30: LEDs (Page 57)) are automatically reset when the system returns to normal. An automatic restart is initiated and the 3RW restarted if a start command is present at the input. If you do not want the motor to start automatically, you must integrate suitable additional components, e.g. phase failure or load monitoring devices, into the control and main circuits.

(3) Alternatively, the motor feeder can be assembled as a fuseless or fused version with type of coordination 1 or 2. For the assignment of fuses and switching devices, refer to chapter Technical data (Page 125).

15.6.2 Control of the 3RW40 with a main contactor

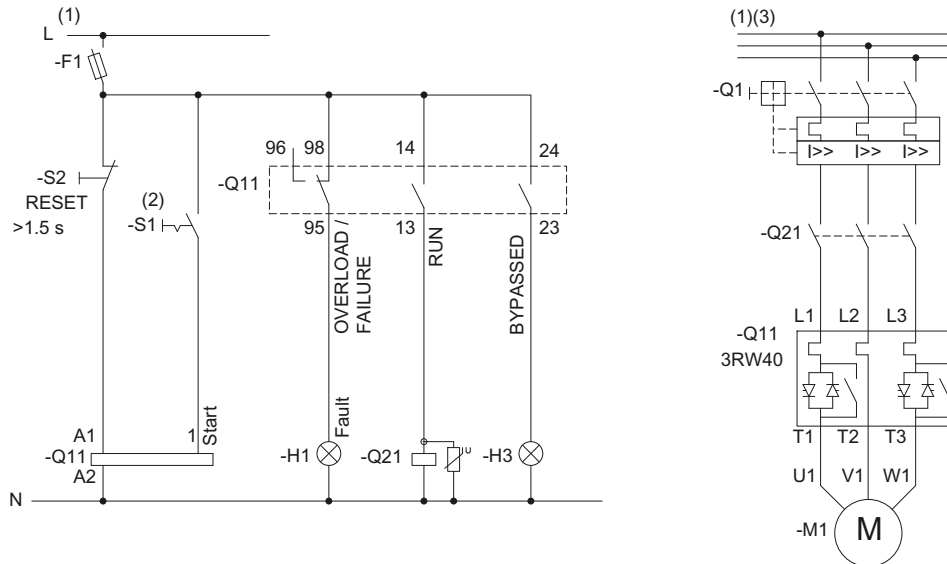

Figure 15-11 Wiring of the 3RW402 - 3RW404 control circuit and 3RW402 - 3RW404 main circuit

Note

If a soft stop is required, the function of output 13/14 must be reparameterized to "RUN" (refer to Commissioning the 3RW40 (Page 108)).

(1) For permissible main and control voltage values (dependent on article number), refer to chapter Technical data (Page 125).

! WARNING

(2) Automatic restart. Can result in death, serious injury, or property damage.

The start command (e.g. issued by the PLC or switch S1) must be reset prior to issuing a RESET command because the motor attempts to restart again automatically following this RESET command if a start command is still present. This particularly applies if the motor protection has tripped. For safety reasons, you are advised to integrate the group fault output (terminals 95 and 96) in the controller.

(3) Alternatively, the motor feeder can be assembled as a fuseless or fused version with type of coordination 1 or 2. For the assignment of fuses and switching devices, refer to chapter Technical data (Page 125).

For the optional thermistor motor protection evaluation, refer to Typical circuit for the optional thermistor motor protection evaluation (Page 147).

15.7 Reversing circuit

15.7.1 3RW30 reversing circuit

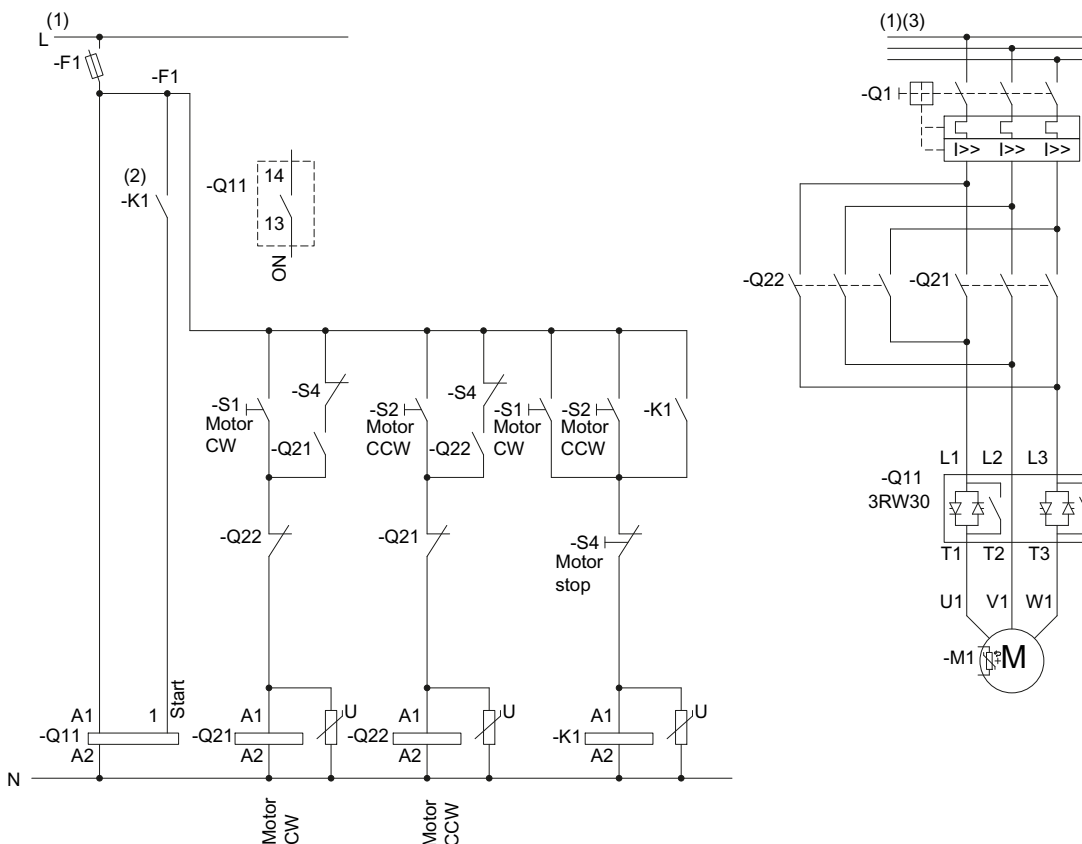

Figure 15-12 Wiring of the 3RW30 control and main circuits

(1) For permissible main and control voltage values (dependent on article number), refer to chapter Technical data (Page 125).

WARNING

(2) Automatic restart. Can result in death, serious injury, or property damage.

Faults caused by incorrect control voltage, a missing load, or a phase failure (refer to chapter 3RW30: LEDs (Page 57)) are automatically reset when the system returns to normal. An automatic restart is initiated and the 3RW restarted if a start command is present at the input. If you do not want the motor to start automatically, you must integrate suitable additional components, e.g. phase failure or load monitoring devices, into the control and main circuits.

(3) Alternatively, the motor feeder can be assembled as a fuseless or fused version with type of coordination 1 or 2. For the assignment of fuses and switching devices, refer to chapter Technical data (Page 125).

15.7.2 3RW40 reversing circuit

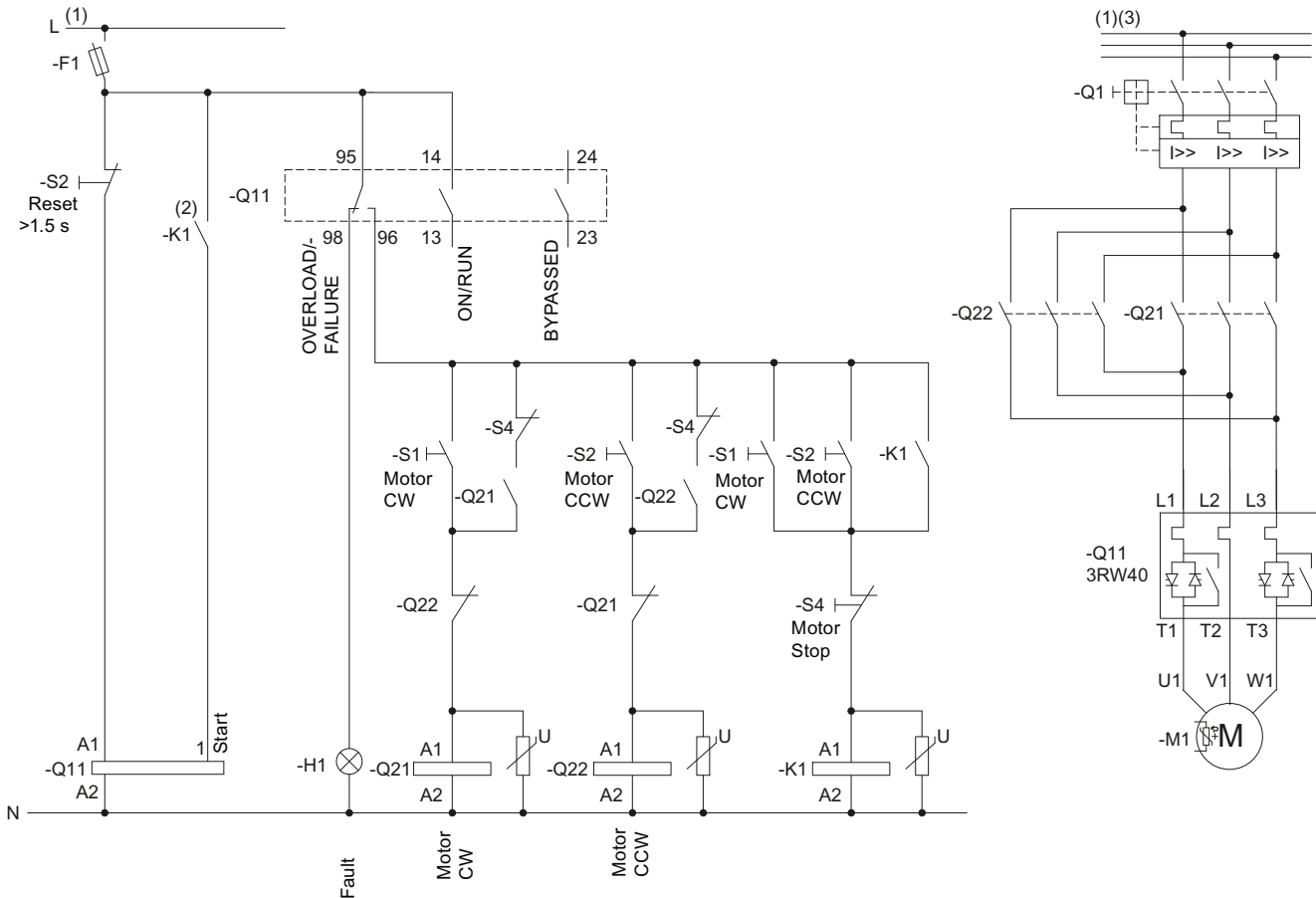

Figure 15-13 Wiring of the 3RW402 - 3RW404 control circuit and 3RW402 - 3RW404 main circuit

(1) For permissible main and control voltage values (dependent on article number), refer to chapter Technical data (Page 125).

⚠ WARNING

(2) Automatic restart can result in death, serious injury, or property damage.

The start command (e.g. issued by the PLC or switch S1) must be reset prior to issuing a RESET command because the motor attempts to restart again automatically following this RESET command if a start command is still present. This particularly applies if the motor protection has tripped. For safety reasons, you are advised to integrate the group fault output (terminals 95 and 96) in the controller.

(3) Alternatively, the motor feeder can be assembled as a fuseless or fused version with type of coordination 1 or 2. For the assignment of fuses and switching devices, refer to chapter Technical data (Page 125).

For the optional thermistor motor protection evaluation, refer to Typical circuit for the optional thermistor motor protection evaluation (Page 147).

Note

No soft stop possible. Set the stopping time to 0 s with the potentiometer.

15.8 Control of a magnetic parking brake

15.8.1 3RW30 motor with magnetic parking brake

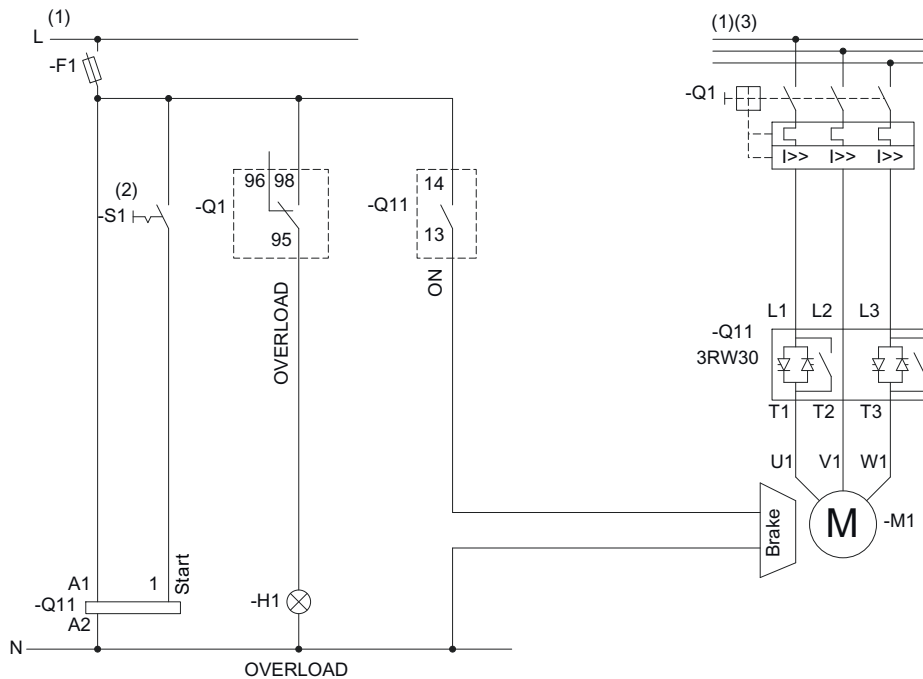

Figure 15-14 Wiring of the 3RW30 control and main circuits

(1) For permissible main and control voltage values (dependent on article number), refer to chapter Technical data (Page 125).

⚠ WARNING

(2) Automatic restart. Can result in death, serious injury, or property damage.

Faults caused by incorrect control voltage, a missing load, or a phase failure (refer to chapter 3RW30: LEDs (Page 57)) are automatically reset when the system returns to normal. An automatic restart is initiated and the 3RW restarted if a start command is present at the input. If you do not want the motor to start automatically, you must integrate suitable additional components, e.g. phase failure or load monitoring devices, into the control and main circuits.

(3) Alternatively, the motor feeder can be assembled as a fuseless or fused version with type of coordination 1 or 2. For the assignment of fuses and switching devices, refer to chapter Technical data (Page 125).

15.8.2 3RW402 - 3RW404, control of a motor with a magnetic parking brake

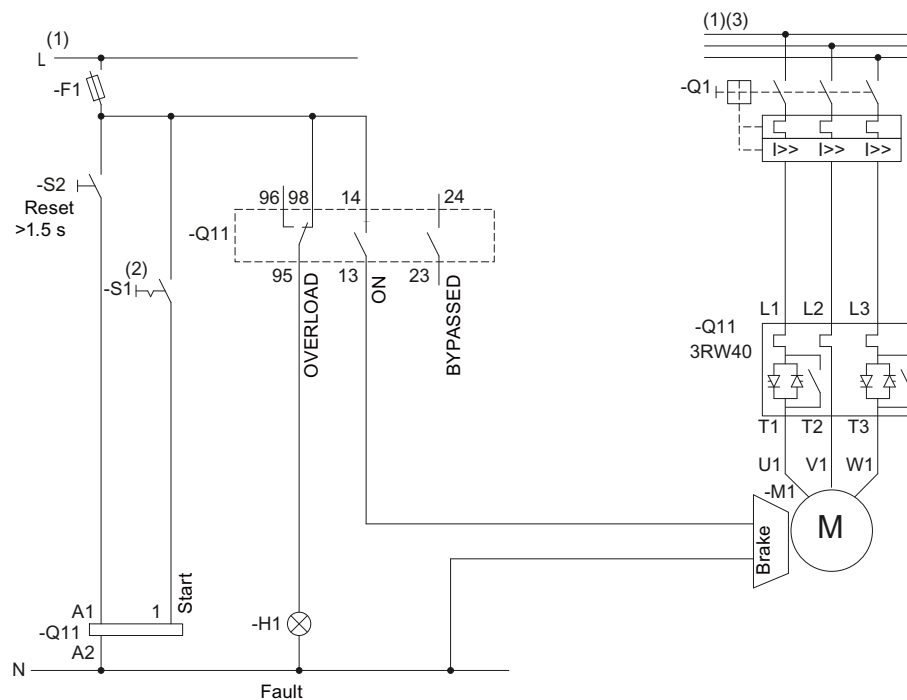

Figure 15-15 Emergency stop wiring of the 3RW402 - 3RW404 control circuit / main circuit

(1) For permissible main and control voltage values (dependent on article number), refer to chapter Technical data (Page 125).

⚠ WARNING

(2) Automatic restart. Can result in death, serious injury, or property damage.

The start command (e.g. issued by the PLC or switch S1) must be reset prior to issuing a RESET command because the motor attempts to restart again automatically following this RESET command if a start command is still present. This particularly applies if the motor protection has tripped. For safety reasons, you are advised to integrate the group fault output (terminals 95 and 96) in the controller.

(3) Alternatively, the motor feeder can be assembled as a fuseless or fused version with type of coordination 1 or 2. For the assignment of fuses and switching devices, refer to chapter Technical data (Page 125).

For the optional thermistor motor protection evaluation, refer to Typical circuit for the optional thermistor motor protection evaluation (Page 147).

Note

No soft stop possible. Set the stopping time to 0 s with the potentiometer.

15.9 EMERGENCY STOP

15.9.1 3RW30 EMERGENCY STOP and 3SK1 safety relay

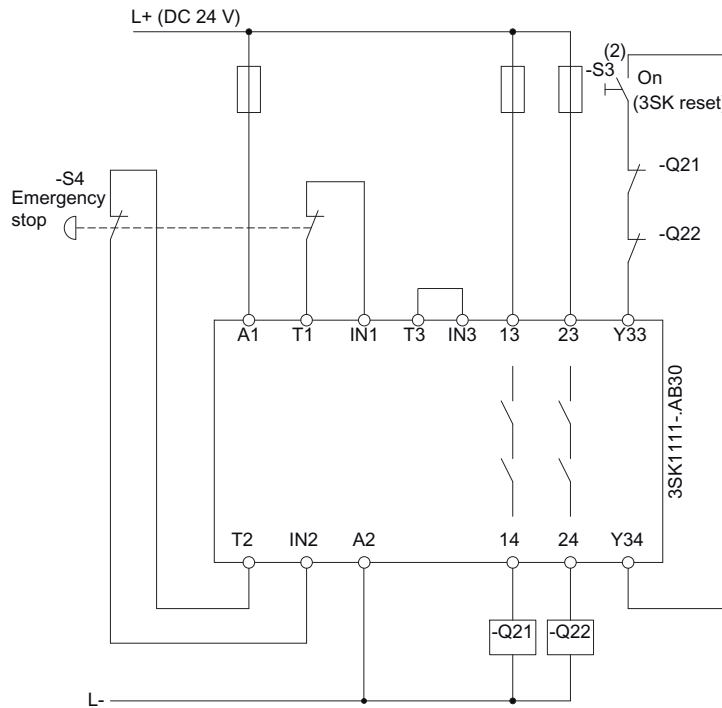

Figure 15-16 Wiring of the EMERGENCY STOP control circuit and the 3SK1 safety relay

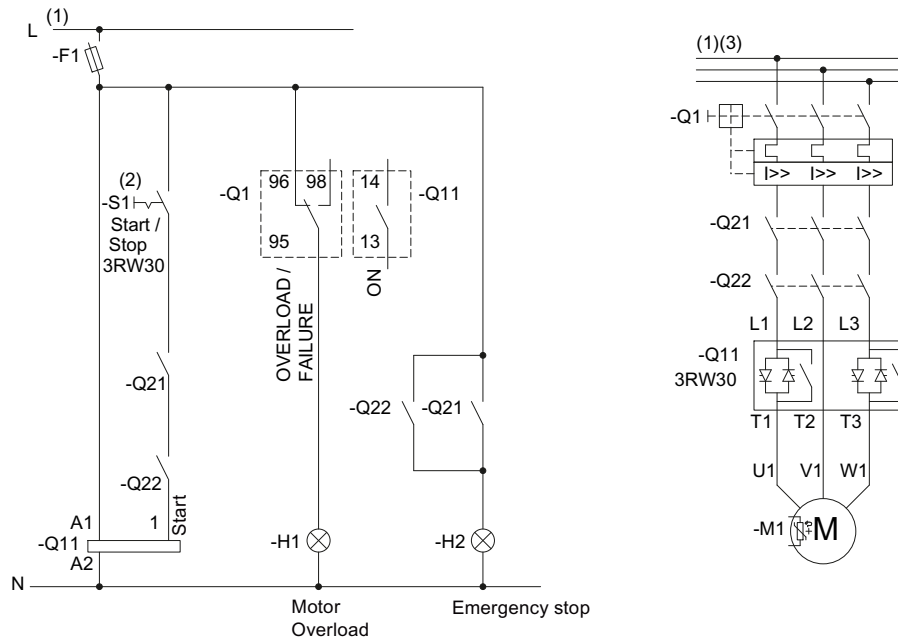

Figure 15-17 Wiring of the 3RW30 control and main circuits

(1) For permissible main and control voltage values (dependent on article number), refer to chapter Technical data (Page 125).

<p>⚠ WARNING</p> <p>(2) Automatic restart. Can result in death, serious injury, or property damage.</p> <ul style="list-style-type: none"> - If the 3SK1 is reset - Faults caused by incorrect control voltage, a missing load, or a phase failure (refer to chapter 3RW30: LEDs (Page 57)) are automatically reset when the system returns to normal. <p>An automatic restart is initiated and the 3RW restarted if a start command is present at the input.</p> <p>If you do not want the motor to start automatically, you must integrate suitable additional components, e.g. phase failure or load monitoring devices, into the control and main circuits.</p>

(3) Alternatively, the motor feeder can be assembled as a fuseless or fused version with type of coordination 1 or 2. For the assignment of fuses and switching devices, refer to chapter Technical data (Page 125).

15.9.2 3RW402 - 3RW404 EMERGENCY STOP and 3SK1 safety relay

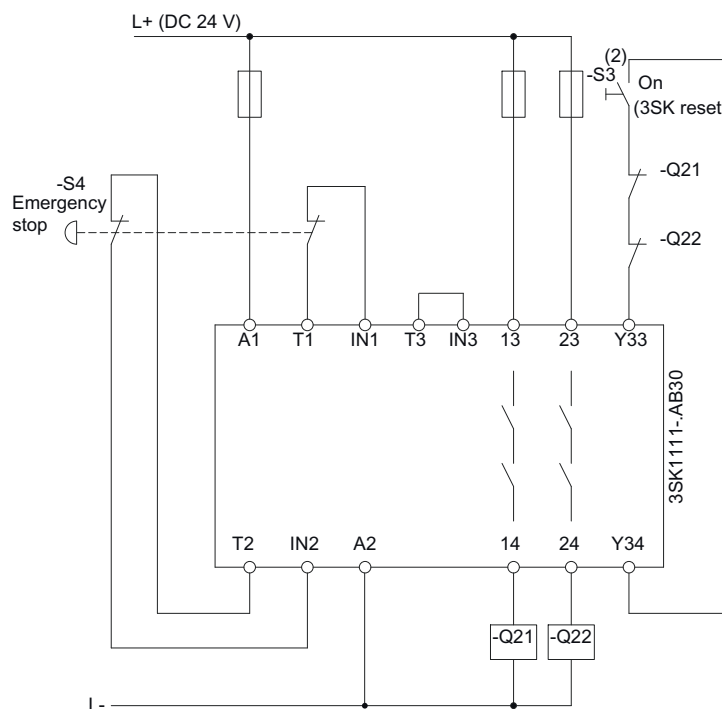

Figure 15-18 Wiring of the EMERGENCY STOP control circuit and the 3SK1 safety relay

15.9 EMERGENCY STOP

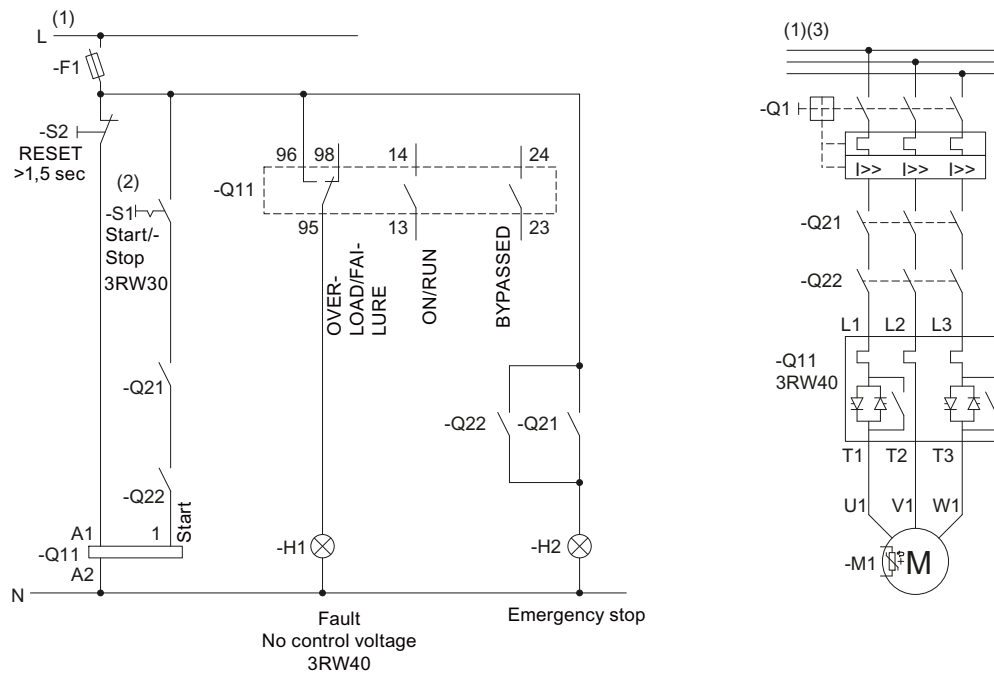

Figure 15-19 Wiring of the 3RW402 - 3RW404 control circuit and 3RW402 - 3RW404 main circuit

(1) For permissible main and control voltage values (dependent on article number), refer to chapter Technical data (Page 125).

! WARNING

(2) Automatic restart can result in death, serious injury, or property damage.

The start command (e.g. issued by the PLC or switch S1) must be reset prior to issuing a RESET command because the motor attempts to restart again automatically following this RESET command (3SK1 or 3RW) if a start command is still present. This particularly applies if the motor protection has tripped. For safety reasons, you are advised to integrate the group fault output (terminals 95 and 96) in the controller.

(3) Alternatively, the motor feeder can be assembled as a fuseless or fused version with type of coordination 1 or 2. For the assignment of fuses and switching devices, refer to chapter Technical data (Page 125).

For the optional thermistor motor protection evaluation, refer to Typical circuit for the optional thermistor motor protection evaluation (Page 147).

Note

If the soft stop function is set (potentiometer stopping time set to >0 s) and the emergency stop circuit is tripped, a "Missing load voltage, phase failure / missing load" fault may be indicated on the soft starter. In this case, the soft starter must be reset according to the selected RESET MODE.

15.10 3RW and contactor for emergency starting

15.10.1 3RW30 and contactor for emergency starting

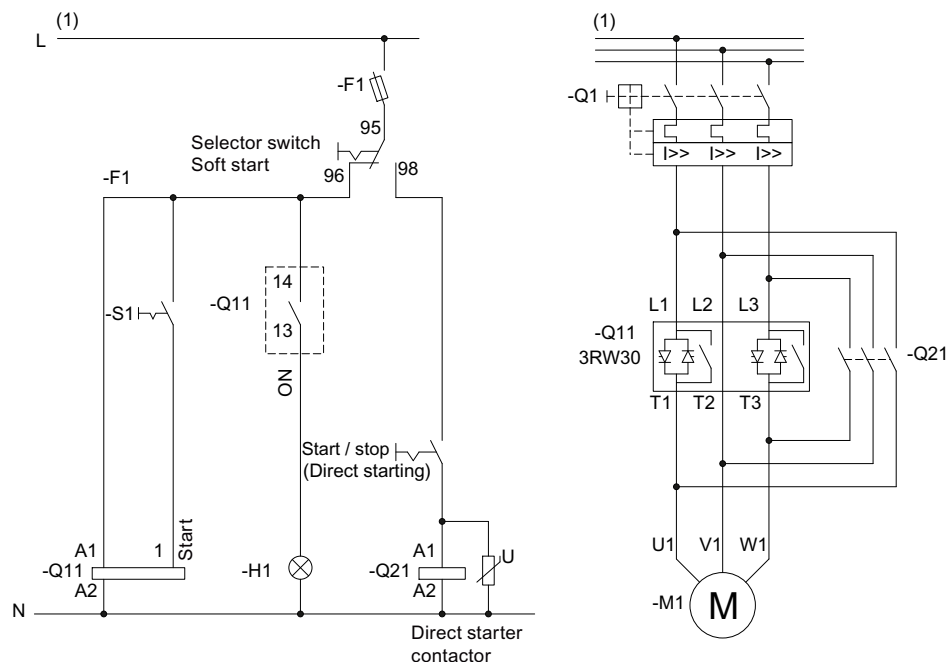

Figure 15-20 Wiring of the 3RW30 control and main circuits

(1) For permissible main and control voltage values (dependent on article number), refer to chapter Technical data (Page 125).

⚠ WARNING

(2) Automatic restart. Can result in death, serious injury, or property damage.

Faults caused by incorrect control voltage, a missing load, or a phase failure (refer to Troubleshooting chapter) are automatically reset when the system returns to normal. An automatic restart is initiated and the 3RW restarted if a start command is present at the input. If you do not want the motor to start automatically, you must integrate suitable additional components, e.g. phase failure or load monitoring devices, into the control and main circuits.

(3) Alternatively, the motor feeder can be assembled as a fuseless or fused version with type of coordination 1 or 2. For the assignment of fuses and switching devices, refer to chapter Technical data (Page 125).

15.10.2 3RW40 and contactor for emergency starting

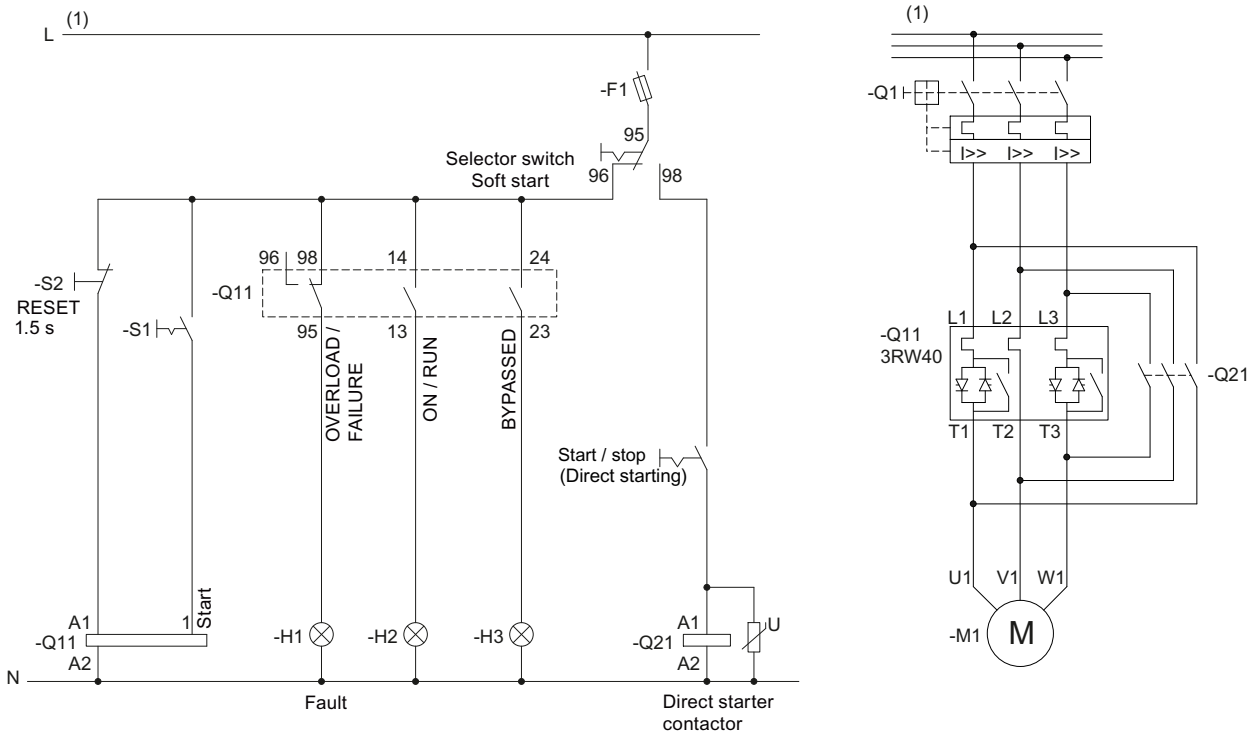

Figure 15-21 Wiring of the 3RW402 - 3RW404 control circuit and 3RW402 - 3RW404 main circuit

(1) For permissible main and control voltage values (dependent on article number), refer to chapter Technical data (Page 125).

	WARNING
<p>(2) Automatic restart. Can result in death, serious injury, or property damage.</p> <p>The start command (e.g. issued by the PLC or switch S1) must be reset prior to issuing a RESET command because the motor attempts to restart again automatically following this RESET command if a start command is still present. This particularly applies if the motor protection has tripped. For safety reasons, you are advised to integrate the group fault output (terminals 95 and 96) in the controller.</p>	

(3) Alternatively, the motor feeder can be assembled as a fuseless or fused version with type of coordination 1 or 2. For the assignment of fuses and switching devices, refer to chapter Technical data (Page 125).

For the optional thermistor motor protection evaluation, refer to Typical circuit for the optional thermistor motor protection evaluation (Page 147).

15.11 Dahlander / multispeed motor

15.11.1 3RW30 and Dahlander motor starting

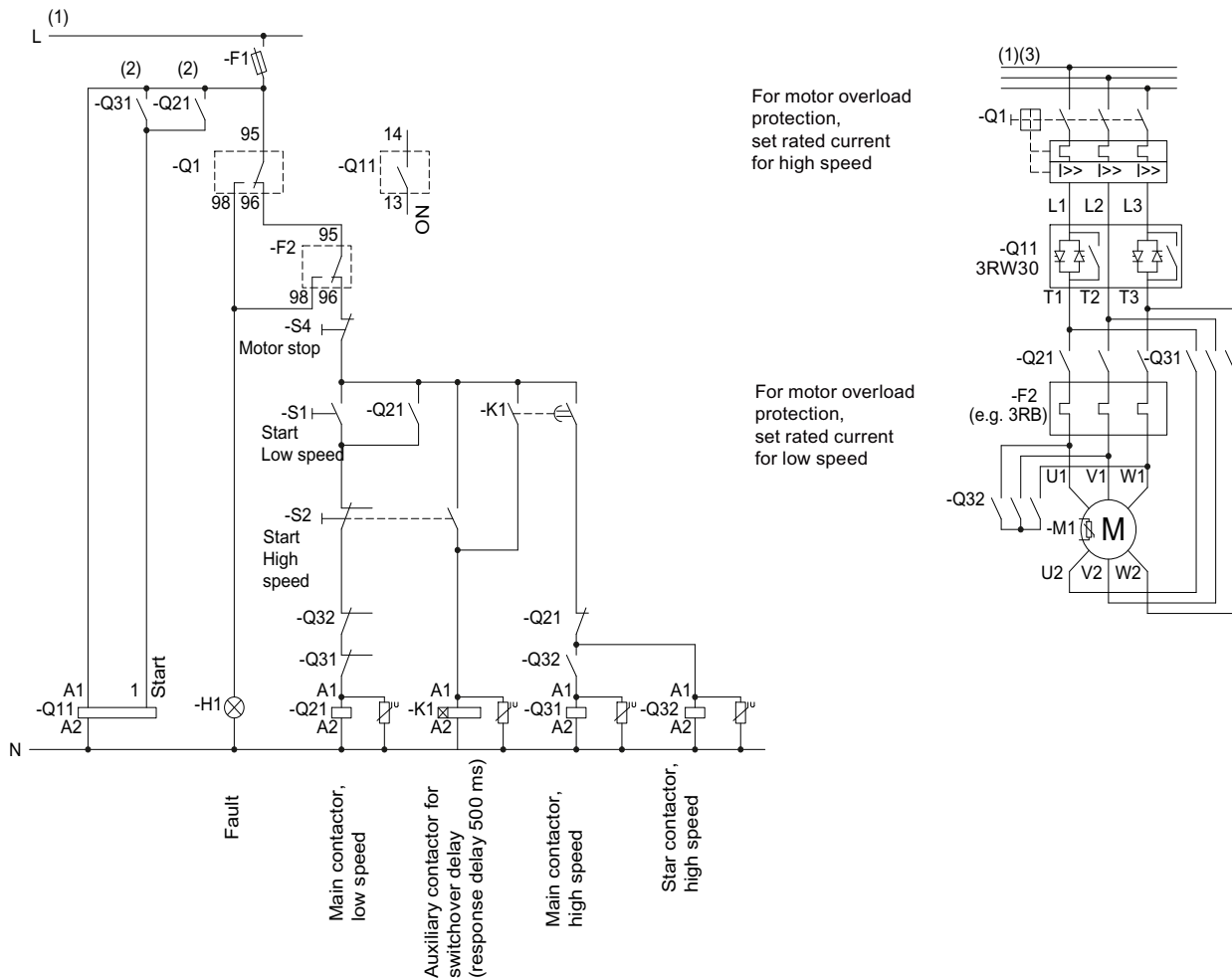

Figure 15-22 Wiring of the 3RW30 control and main circuits

(1) For permissible main and control voltage values (dependent on article number), refer to chapter Technical data (Page 125).

⚠ WARNING

(2) Automatic restart. Can result in death, serious injury, or property damage.

Faults caused by incorrect control voltage, a missing load, or a phase failure (refer to chapter 3RW30: LEDs (Page 57)) are automatically reset when the system returns to normal. An automatic restart is initiated and the 3RW restarted if a start command is present at the input. If you do not want the motor to start automatically, you must integrate suitable additional components, e.g. phase failure or load monitoring devices, into the control and main circuits.

15.11 Dahlander / multispeed motor

(3) Alternatively, the motor feeder can be assembled as a fuseless or fused version with type of coordination 1 or 2. For the assignment of fuses and switching devices, refer to chapter Technical data (Page 125).

15.11.2 3RW402 - 3RW404 and Dahlander motor starting

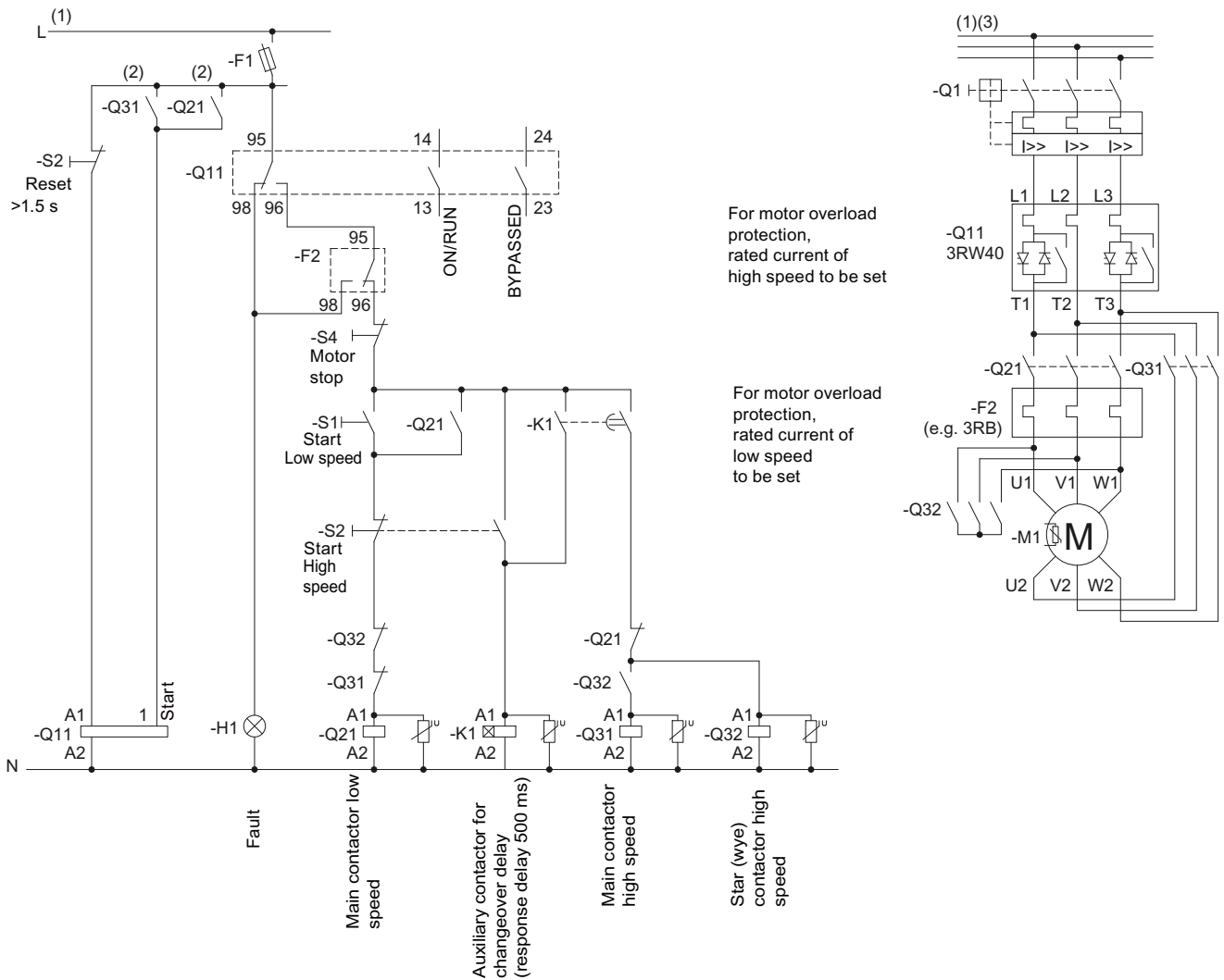

Figure 15-23 Wiring of the 3RW402 - 3RW404 control circuit and 3RW402 - 3RW404 main circuit

(1) For permissible main and control voltage values (dependent on article number), refer to chapter Technical data (Page 125).

 **WARNING**

(2) Automatic restart. Can result in death, serious injury, or property damage.

The start command (e.g. issued by the PLC or switch S1) must be reset prior to issuing a RESET command because the motor attempts to restart again automatically following this RESET command if a start command is still present. This particularly applies if the motor protection has tripped. For safety reasons, you are advised to integrate the group fault output (terminals 95 and 96) in the controller.

(3) Alternatively, the motor feeder can be assembled as a fuseless or fused version with type of coordination 1 or 2. For the assignment of fuses and switching devices, refer to chapter Technical data (Page 125).

For the optional thermistor motor protection evaluation, refer to Typical circuit for the optional thermistor motor protection evaluation (Page 147).

Note

No soft stop possible. Set the stopping time to 0 s with the potentiometer.

Appendix

A.1 Configuration data

Motor data

Siemens motor?

Rated power:	kW
Rated voltage:	V
Mains frequency:	Hz
Rated current:	A
Starting current:	A
Rated speed:	rpm
Rated torque:	Nm
Breakdown torque:	Nm
Mass moment of inertia:	kg*m ²

Speed / torque characteristic curve

(The speed increments of the value pairs do not have to be equal)

n _M 1/m												"n _{syn} "
M _M / M _B												

Speed / current characteristic curve

(The speed increments of the value pairs do not have to be equal)

n _M 1/m											"n _{syn} "
I _M / I _B											

Load data

Load type (e.g. pump, mill etc.):

Rated speed:	rpm
Rated torque or rated power	Nm or kW
Mass moment of inertia (load-specific)	kg*m ²
Mass moment of inertia (motor-specific)	kg*m ²

A.1 Configuration data

Speed / torque characteristic curve

(The speed increments of the value pairs do not have to be equal)

n_L 1/m													"n _{syn} "
M_L / M_B													

Start conditions

Starting frequency

Starts

Switching cycles: Run-up time
 Operating time
 Idle time
 Stopping time

Ambient temperature

°C

	Yes	Value
Starting current limitation?	<input type="checkbox"/>
Acceleration torque limitation?	<input type="checkbox"/>
Maximum starting time?	<input type="checkbox"/>

Personal details

Last name, first name:

Company:

Department:

Street:

Zip code, town/city:

Country:

Phone:

Fax:

Email:

A.2 Table of parameters used

You can document your parameter settings in the table below.

		3RW40 parameters								
Plant identifier	Installed 3RW type	Parameters 3RW30 or 3RW40				3RW40 parameters				
		U starting %	t ramp-up s	t ramp-down s	le motor A	Factor le limit value	CLASS value	RESET MODE LED	Output ON / RUN	Thermistor
Pump XYZ	3RW4038-1TB04							Manual (off) <input type="checkbox"/> AUTO (yellow) <input type="checkbox"/> Remote (green) <input checked="" type="checkbox"/>	ON <input type="checkbox"/> RUN <input checked="" type="checkbox"/>	PTC <input type="checkbox"/> Klixon <input checked="" type="checkbox"/>
	3RW__-B__							Manual (off) <input type="checkbox"/> AUTO (yellow) <input type="checkbox"/> Remote (green) <input type="checkbox"/>	ON <input type="checkbox"/> RUN <input type="checkbox"/>	PTC <input type="checkbox"/> Klixon <input type="checkbox"/>
	3RW__-B__							Manual (off) <input type="checkbox"/> AUTO (yellow) <input type="checkbox"/> Remote (green) <input type="checkbox"/>	ON <input type="checkbox"/> RUN <input type="checkbox"/>	PTC <input type="checkbox"/> Klixon <input type="checkbox"/>
	3RW__-B__							Manual (off) <input type="checkbox"/> AUTO (yellow) <input type="checkbox"/> Remote (green) <input type="checkbox"/>	ON <input type="checkbox"/> RUN <input type="checkbox"/>	PTC <input type="checkbox"/> Klixon <input type="checkbox"/>
	3RW__-B__							Manual (off) <input type="checkbox"/> AUTO (yellow) <input type="checkbox"/> Remote (green) <input type="checkbox"/>	ON <input type="checkbox"/> RUN <input type="checkbox"/>	PTC <input type="checkbox"/> Klixon <input type="checkbox"/>
	3RW__-B__							Manual (off) <input type="checkbox"/> AUTO (yellow) <input type="checkbox"/> Remote (green) <input type="checkbox"/>	ON <input type="checkbox"/> RUN <input type="checkbox"/>	PTC <input type="checkbox"/> Klixon <input type="checkbox"/>

Index

A

Ambient temperature, 90, 92
Application examples, 86
 Heavy-duty starting, 87
 Normal starting, 86
Applications, 32
 For current limiting, 41
 Soft stop, 43
Assembly type, 93, 97
ATEX, 46, 134

B

Bypass contacts, 107, 115, 121
Bypass mode, 30
BYPASSED function, 54

C

Capacitors, 74
CLASS 10, 86, 87, 118
CLASS 15, 118
CLASS 20, 88, 118
CLASS potentiometer, 117
CLASS setting, 44, 45, 117
Commissioning, 103, 108
Configuration, 83
Contact, 69
Current limiting, 37, 40, 41, 112, 113
Current limiting value, 40, 113

D

Degree of protection, 68
Diagnostics, 58, 61
Direct mounting, 68
Disconnecter, 69
Documentation of parameters, 175
Documentation of settings, 175

F

Fan, 65
FAQs, 11
Fault signals, 51, 58, 61, 71

Five safety rules for electricians, 26
Full motor protection, 44

H

Heavy-duty starting, 73, 87
 Ambient temperature, 88
 General conditions and constraints, 88
 Installation altitude, 88
 ON time, 88
 Parameter settings, 87

I

le potentiometer, 117
IECEX, 46
Increased safety, 134
Industry Mall, 10
Installation altitude, 90, 92
 CLASS 10, 87
 CLASS 20, 88
 Normal starting, 87
Internet addresses
 Brochures, 10
 Catalogs, 10
 Industry Mall, 10
 Online configurator, 10
Intrinsic device protection, 48

M

Manuals, 11
Maximum starting time, 87, 88
Method of operation
 Soft starters, 30
 Two-phase control, 30
Motor current settings, 118
Motor overload protection, 44
Motor protection function, 44
Motor ramp-up detection, 115
Motor ramp-up time, 107
Mounting position, 93, 97
 Horizontal, 65
 Vertical, 65, 90

N

- Natural stop, 42
- Normal starting, 83, 86, 126, 134
 - Ambient temperature, 87
 - General conditions and constraints, 87
 - Installation altitude, 87
 - ON time, 87
 - Parameter settings, 86

O

- ON function, 53, 121
- ON time, 89
 - Heavy-duty starting, 88
 - Normal starting, 87
- Output contact, 107, 121
- Overdimensioning, 114
- Overload protection, 45

P

- Phase angle control, 30
- Polarity balancing, 30, 31
- Protection against voltage failure, 45
- PTC thermistors, 45
- Pump stop, 43

R

- Ramp time, 37, 105, 106, 111
- Ramp-down time, 43, 116
- Ramp-up, 115
- Ramp-up detection, 38, 41, 86
- Ramp-up time, 107
 - 3RW30, 107
 - 3RW40, 111
- Rated data
 - Reduction, 90
- Rated operational current, 117
- Reactive power compensation, 21
- Recovery time
 - Intrinsic device protection, 48
 - Motor overload protection, 45
 - Thermistor motor protection, 46
- References, 11
- RUN function, 53, 121

S

- Safety rules, 26
- Screw-type technology, 77
- Selection criteria, 32
- Semiconductor fuses, 48
- Side-by-side assembly, 67
- Simulation Tool for Soft Starters, 99
- SITOR, 48
- SITOR semiconductor fuses, 48
- Soft start, 29, 105, 110
- Soft stop, 29, 116
- Spring-loaded technology, 77
- Standalone assembly, 67
- Start, 29
- Start modes, 83
- Starting current asymmetry, 40, 113
- Starting time
 - Maximum, 87, 88
- Starting torque, 37
- Starting voltage, 37
- Startup class, 86
- Stop, 29
- Stop modes, 42
- Stop without load, 42, 116
- Stopping torque, 43
- Switching frequency, 89, 98

T

- t potentiometer, 111, 116
- Temperature sensor, 45
- Thermistor motor protection, 44, 46, 119, 134, 147
- Thermoclick sensors, 45
- Three-phase induction motor, 29
- Thyristor, 30
- Thyristor protection, 48
- Trip class, 44, 45, 117
- Troubleshooting, 58, 61
- Two-phase control, 30
- Two-phase soft starters, 30
- Type of coordination, 48, 70, 71, 72, 73, 132
 - 1, 132, 142
 - 2, 132, 142

V

- Voltage ramp, 37, 39, 105, 110, 111

W

Water hammer, 43

X

xle potentiometer, 113

